

EDDC

Equipment Distribution
Centre

AUDIO GUIDEBOOK

Use the following link to make a reservation online:

[https://wchout.ccs.ryerson.ca/sso/patron#/
/](https://wchout.ccs.ryerson.ca/sso/patron#/)

Andy Kufluk Equipment Distribution Centre

80 Gould St. Room RCC-166

Toronto, ON

(416) 979-5000 ext.557534

**Toronto
Metropolitan
University**

**The
Creative
School**

Table of Contents

EDC Audio Guidebook

Audio Accessories	8
Boompole Holder	9
Boompole w/ Pistol Grip	9
Cymbal Kits	9
DI Boxes - Passive	9
Drum Mic Kit	9
Drum Tuning Key	9
Feedback Suppressor	10
Headphones	10
Headphones - 7.1 Surround	10
Headphones - USB w/ mic	10
High Hat Clutch	10
Instruments - Acoustic Guitar	10
Instruments - Bass Guitar	11
Instruments - Bongos	11
Instruments - Electric Guitar	11
MIDI Keyboard	11
Matchbox Line Converters	11
Mic Clip - Small	11
Mic Clip - SM 57/58	12
Mic Clip - Shoe Mount	12
Microphone Stand - Floor	12
Microphone Stand - Table	12
Parabolic Dish	12

Table of Contents

EDC Audio Guidebook

Pistol Grip	12
Pop Filter	13
Pro Tools ILOK	13
ReAmper - Xamp	13
Telephone Record Adaptor	13
Windsock - Blimp	13
Windsock - Indoor	13
Windsock - Outdoor	14
Windsock - SM58/H4N	14
Microphones	15
Boundary - Condenser	16
AKG Crown PCC-130	16
Audio Technica U851A	17
Camera Mounted Shotgun Condenser	18
Shure VP83F Lenshopper	18
Capacitor - Condenser	19
AKG C414B XLII	19
Dynamic	21
Electro-Voice RE20	21
Heil Sound PR 30	22
Heil Sound PR 40	23
Sennheiser 421-II	24
Shure SM57	25

Table of Contents

EDC Audio Guidebook

Shure SM7B	26
Dynamic - Handheld	27
Audio-Technica AT8004	27
Beyerdynamic TG-X 48	28
Electro Voice EV635A	29
Electro Voice RE50N/D-B	30
Sennheiser MD 46	31
Shure SM58	32
Sony F-112	33
Dynamic - Kick Drum Mic	34
Shure Beta 52A	34
AKG D112	35
Dynamic - Two Way	36
AKG D200E	36
AKG D202E	37
AKG D224E	38
Large Diaphragm Condenser	39
Apex 420	39
Audio Technica AT4050	40
Blue Baby Bottle	41
Blue Blueberry	42
Kel HM-7U	43
MXL 770	44
Neumann TLM 103	45

Table of Contents

EDC Audio Guidebook

Neumann TLM 49	46
Rode NT2000	47
Rode NT1	48
Rode NT2-A	49
Large Diaphragm Condenser - Dual	50
AKG C3000	50
Ribbon	51
Apex 215	51
Coles 4038	52
Shotgun - Mini Condenser	53
Panasonic AG MC-200	53
Shotgun - Giant	54
Sony C-76	54
Shotgun - Condenser	55
Sennheiser Mke 600	55
Audio Technica AT897	56
Sennheiser ME66	57
Rode NTG2	58
Small Diaphragm Condenser	59
Earthworks SR30 Pair	59
Small Diaphragm Pencil Condenser	60
Apex 170	60
Rode NT5	61
Scheopes CMC-5U	62

Table of Contents

EDC Audio Guidebook

Stereo Small Diaphragm Condenser	63
Audio Technica AT8022	63
Rode NT4	64
Superlux S502	65
USB Boundary Mic	66
CAD U7	66
MXL uCHAT	66
USB Condenser Mic	67
Blue Snowball	67
Blue Nessie	68
Wired Condenser Lav	69
Audio-Technica AT899	69
Countryman B3	70
Sony ECM-44B	71
Sony ECM-55B	72
Wireless Lav	73
Sennheiser EW100	73
3Dio Free Space Binaural Microphone	74
Recorders, Mixers, DAW's, PA's & Speakers	75
Audio Cart	76
Behringer X32	76
Behringer X32 Compact	76

Table of Contents

EDC Audio Guidebook

Digital Snake	76
iRig Mic Adapter - 1/8"	77
iRig - Lightning Connector	77
Marantz - 661	77
Marantz - 661 MKIII	77
Mixers - 2 Channel Field	78
Mixers - 3 Channel Field	78
Mixers - 6 Channel Field	78
Mixers - Mackie 1202	78
Mixers - Mackie 1604	79
Mixers - Onyx 1620	79
Powered Studio Monitors	79
Speakers - Computer	79
Speakers - Ediol	80
Speakers - PA (12",15")	80
USB Audio Interface	80
Zoom - F1	80
Zoom - F8	81
Zoom - H2N	81
Zoom - H4N	81
Zoom - H5	81
Zoom - H6	82

Audio Accessories

EDC Audio Guidebook

Boompole Holder



SPECS Holder for Grip C/Stand
(Boombuddy)

AUTHORIZATION: The Creative School

Boompole w/ Pistol Grip



SPECS RODE 10 feet extention)

AUTHORIZATION: The Creative School

Cymbal Kit



SPECS Sabian XS20

AUTHORIZATION: The Creative School

DI Boxes - Passive



SPECS Radial Engineering ProDI

AUTHORIZATION: The Creative School

Drum Mic Kit



SPECS 3x SM57, 1x Beta 52A, 3x
Mounts

AUTHORIZATION: The Creative School

Drum Tuning Key



SPECS Standard Drum Tuning Key

AUTHORIZATION: The Creative School

Feedback Suppressor



SPECS Behringer, 2 Channel Automatic Suppressor

AUTHORIZATION: The Creative School

Headphones



SPECS Over Ear Headphones

AUTHORIZATION: The Creative School

Headphones - 7.1 Surround Headphones - USB w/ Mic



SPECS Turtle Beach 7.1 Surround Headset

AUTHORIZATION: The Creative School



SPECS Everyman Headset

AUTHORIZATION: The Creative School

High Hat Clutch



SPECS Clutch For High Hats

AUTHORIZATION: The Creative School

Intruments - Acoustic Guitar



SPECS Yamaha Acoustic Guitar (CPX500 II NT)

AUTHORIZATION: The Creative School

Intruments - Bass Guitar



SPECS

Fender P-Bass Guitar
(MX11241804)

AUTHORIZATION: The Creative School

Instruments - Bongos



SPECS

2 Bongos, Medium Light Colour

AUTHORIZATION: The Creative School

Instruments - Electric Guitar



SPECS

Epiphone Les Paul Electric Guitar (ELP1HSCH)

AUTHORIZATION: The Creative School

MIDI Keyboard



SPECS

M-Audio Keyrig 49

AUTHORIZATION: The Creative School

Matchbox Line Converter



SPECS

Rolls, 2-way stereo line converter

AUTHORIZATION: The Creative School

Mic Clip - Small



SPECS

Mic clip for shotgun or small mic

AUTHORIZATION: The Creative School

Mic Clip - SM57/58



SPECS Mic clip for SM57/58

AUTHORIZATION: The Creative School

Mic Clip - Shoe Mount



SPECS Shotgun mic shockmount for on-camera use

AUTHORIZATION: The Creative School

Microphone Stand - Floor



SPECS N/A

AUTHORIZATION: The Creative School

Microphone Stand - Table



SPECS N/A

AUTHORIZATION: The Creative School

Parabolic Dish



SPECS JonyJib - Parabolic Mic Dish, requires mic

AUTHORIZATION: The Creative School

Pistol Grip



SPECS Shotgun mic holder for boompoles

AUTHORIZATION: The Creative School

Pop Filter



SPECS Reduce unwanted sounds from being picked up by mic

AUTHORIZATION: The Creative School

Pro Tools ILOK



SPECS Pro Tools 12 License

AUTHORIZATION: The Creative School

ReAmp - Xamp



SPECS Radial Engineering - Active Amp Driver

AUTHORIZATION: The Creative School

Telephone Record Adapter



SPECS Telephone Adaptor for Recording Interviews

AUTHORIZATION: The Creative School

Windsock - Blimp



SPECS Blimp and outdoor windsock

AUTHORIZATION: The Creative School

Windsock - Indoor



SPECS Indoor windsock for shotgun mic

AUTHORIZATION: The Creative School

Windsock - Outdoor



SPECS

Outdoor windsock for
shotgun mic

AUTHORIZATION: The Creative
School

Windsock - SM58 / H4N



SPECS

Indoor windsock for SM58
mics or Zoom H4N

AUTHORIZATION: The Creative
School

Microphones

EDC Audio Guidebook

AKG Crown PCC-130



TYPE Boundary - Condenser

PICKUP Tilted Cardioid

POWER 48v

COMMON USES Interviews, Lectures, Podcasting

SIMILAR MICS AT U851A, PMD661

AUTHORIZATION
The Creative School

Frequency Response:

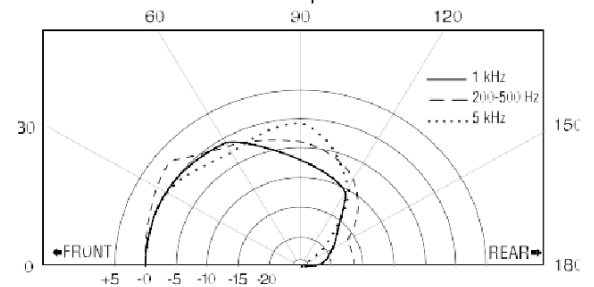
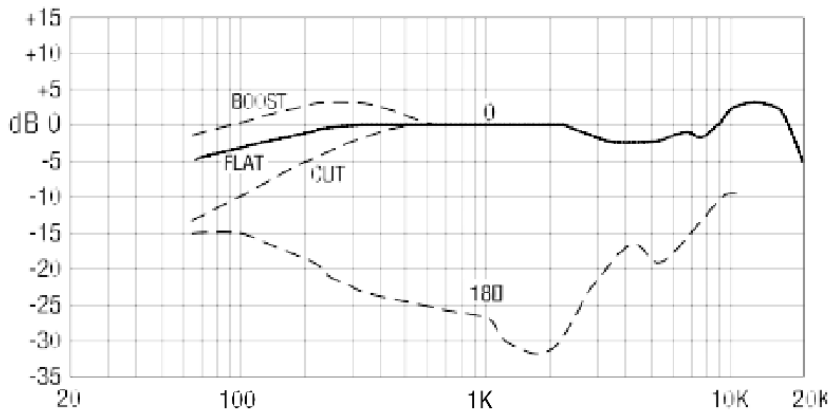

Notes:

- PCC (Phase Coherent Cardioid) technology boosts speech intelligibility
- Easy and discreet setup for recording conversation without a mic stand
- It's fairly directional, so better for recording a single sound source rather than several

Audio Technica U851A



TYPE Boundary - Condenser

PICKUP Half Cardioid

POWER Battery or 48v

COMMON USES Conferencing, Interviews, Piano

SIMILAR MICS PCC-130, PMD661

AUTHORIZATION
The Creative School

Frequency Response:

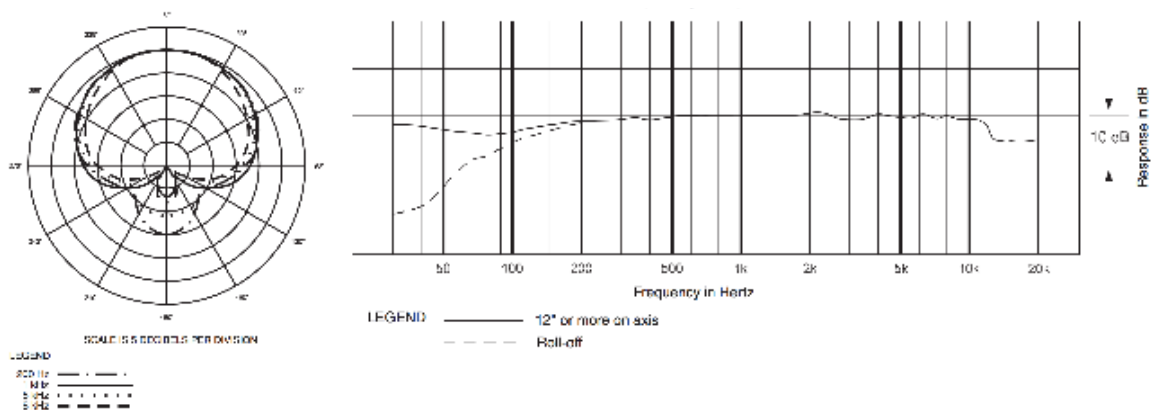

Notes:

- High-quality, multi-use boundary mic
- Simple way to record a conversation or interview without a mic stand
- Mount inside piano in studio or on stage for a great close-mic sound
- Resistant against feedback in live situations

Shure VP83F Lenshopper



TYPE

Camera Mounted Shotgun
Condenser

PICKUP

Supercardioid

POWER

2x AA Batteries

**COMMON
USES**

DSLR Audio

**SIMILAR
MICS**

Rode VideoMic Pro

AUTHORIZATION
The Creative School

Frequency Response:

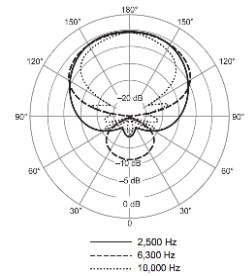
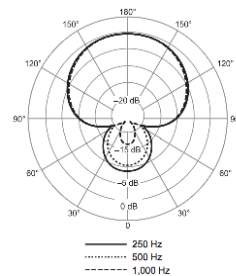
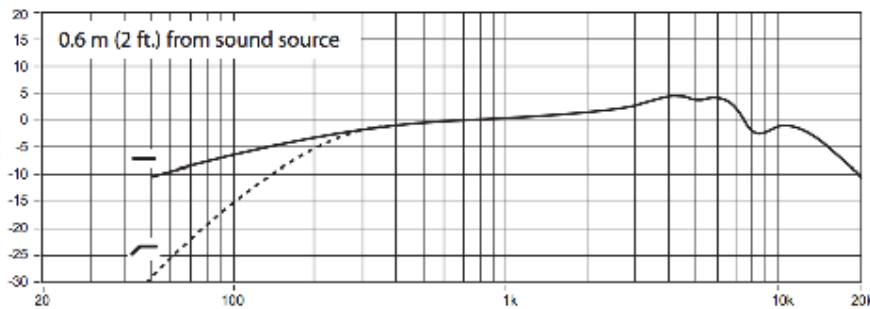

Notes:

- Comes with MicroSD card
- Mini-to-mini connectivity available for output to camera
- Press record button to record. Press again to pause. Hold down record button for 2 seconds to stop.

AKG C414B XLII



TYPE	Capacitor - Condenser
PICKUP	Omni, Figure 8, Cardioid, Wide Card, Super Card
POWER	48V
COMMON USES	Vocals, Kick Drum, Acoustic, Gtr, Piano, Foley
SIMILAR MICS	AT 4050, NT2

AUTHORIZATION
RTA

Frequency Response: *Omnidirectional*

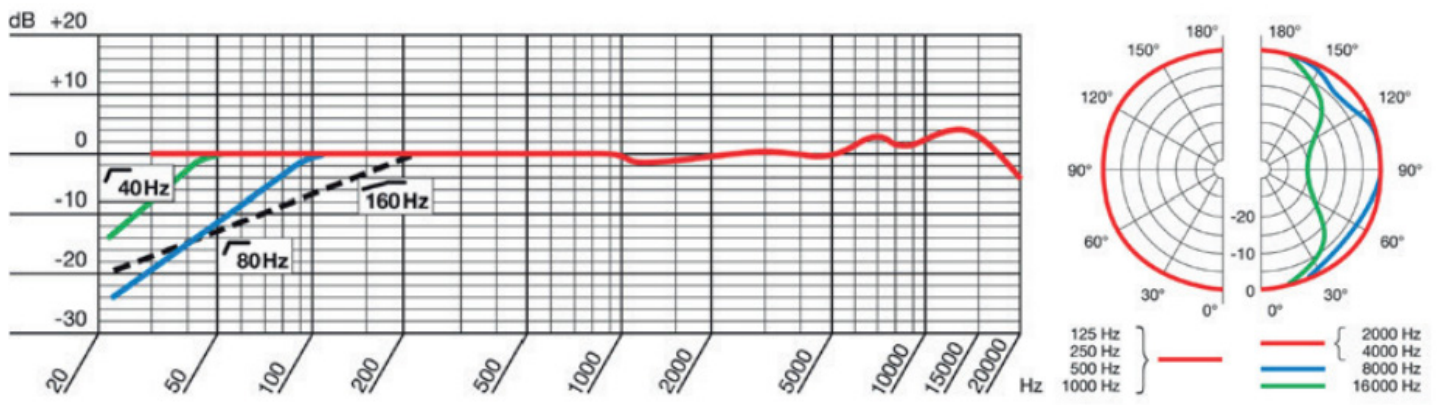
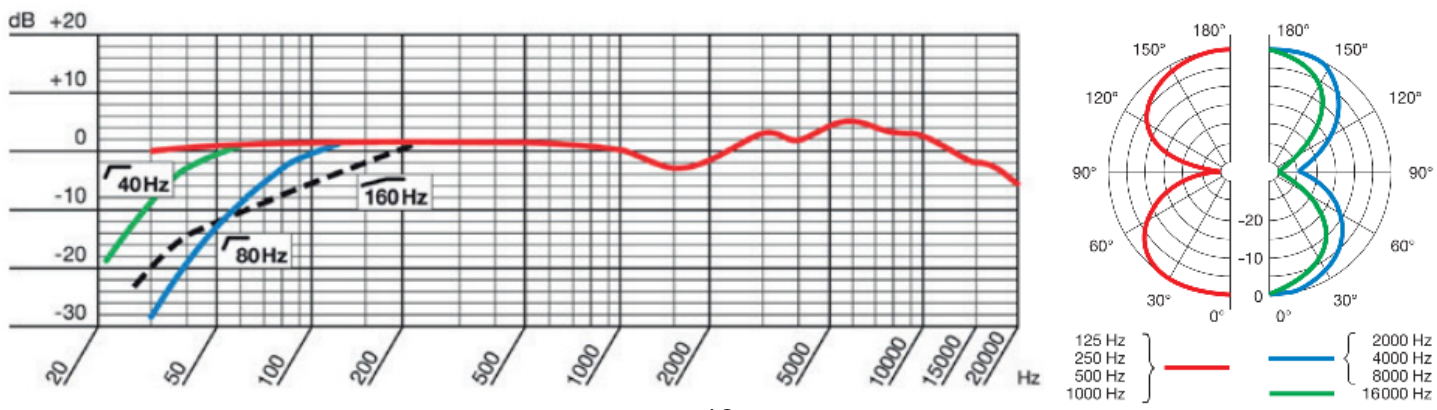
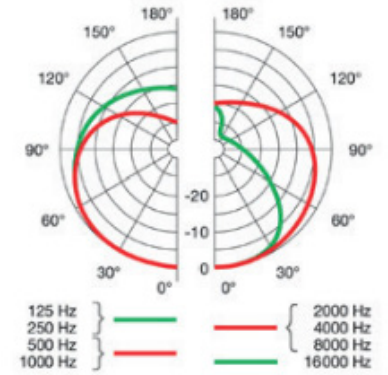
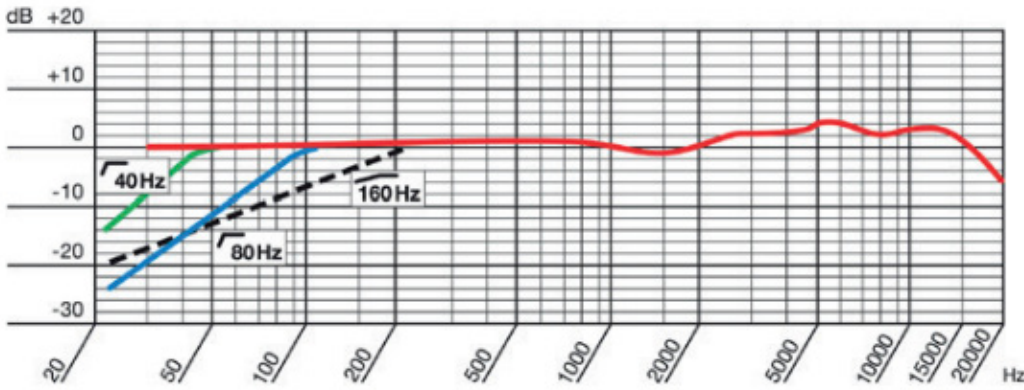

Figure 8



Cardioid



Wide Cardioid

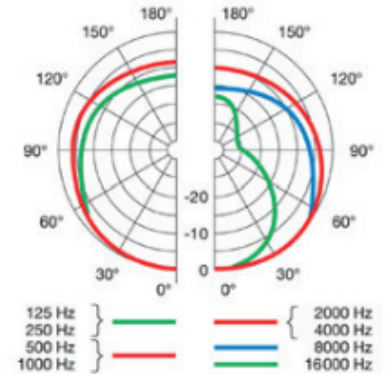
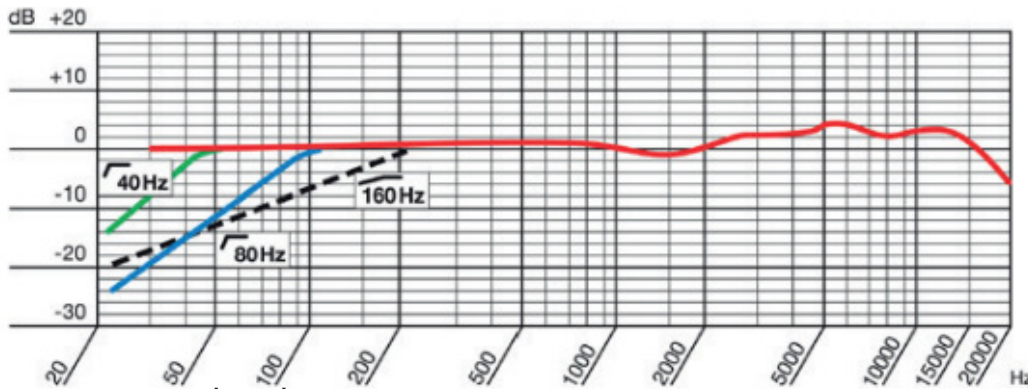

Hypercardioid

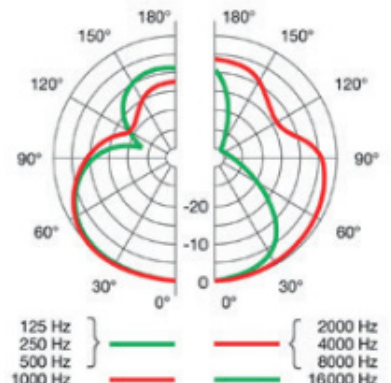
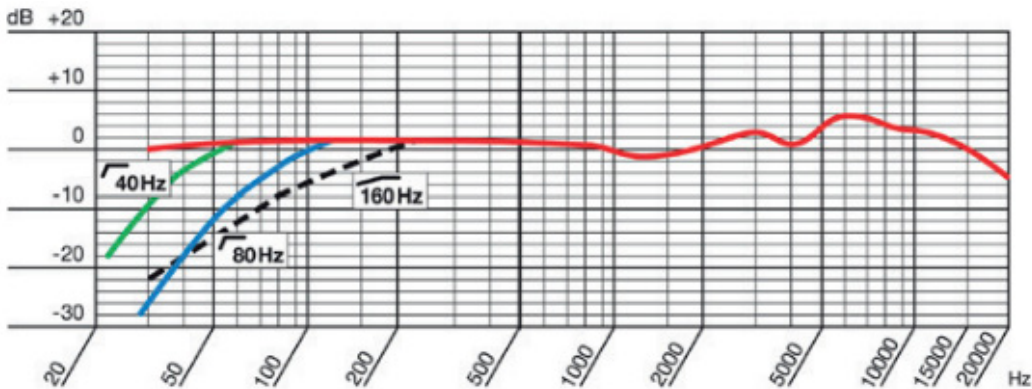

Notes:

- Very versatile, worth trying on anything and everything
- Point side with 'AKG' logo at sound source
Solid red LED means recording,
flashing LED means paused

Electrovoice RE20



TYPE	Dynamic
PICKUP	Cardioid
POWER	None
COMMON USES	Vocals, Bass, Kick Drum, Broadcast
SIMILAR MICS	SM7B, 421, PR 40

**AUTHORIZATION
RTA**

Frequency Response:

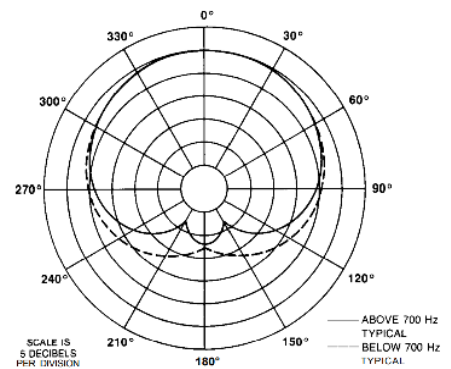
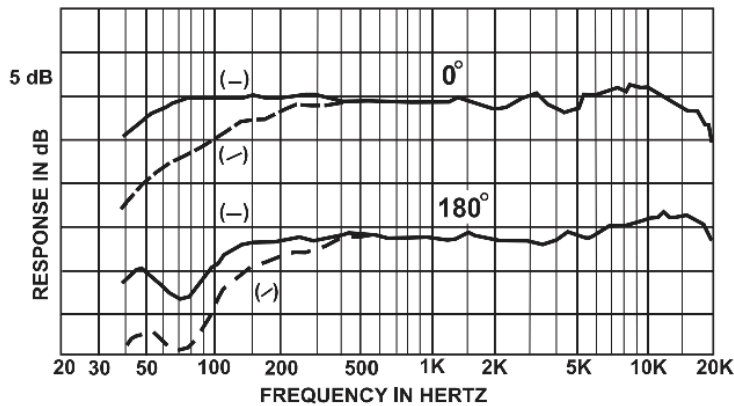

Notes:

- Frequently used as a vocal mic by Thom Yorke of Radiohead both live and in studio
- Unique body design and capsule placement make it immune to proximity effect. Get as close as you need without colouring the sound

Heil Sound PR 30



TYPE	Dynamic
PICKUP	Cardioid
POWER	None
COMMON USES	Drums, Electric Guitar, Loud, Vocals
SIMILAR MICS	PR 40, SM57

AUTHORIZATION
RTA

Frequency Response:

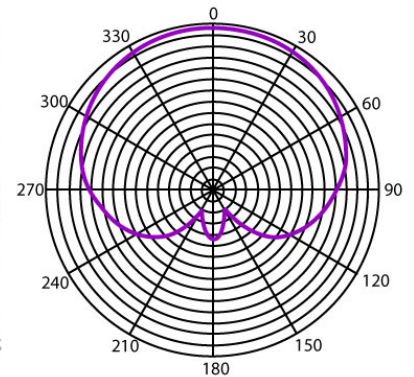
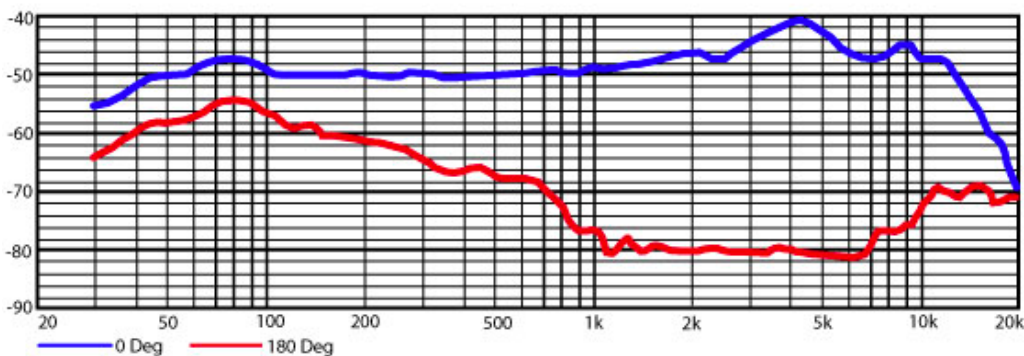

Notes:

- Kurt Ballou's (Converge, Code Orange) favored mic for electric guitar, snare, and bass
- Sounds like a ribbon mic, but able to handle extreme SPLs
-

Heil Sound PR 40



TYPE	Dynamic
PICKUP	Cardioid
POWER	None
COMMON USES	Kick Drum, Bass, Podcast
SIMILAR MICS	SM7B, RE20, MD 421

AUTHORIZATION
RTA

Frequency Response:

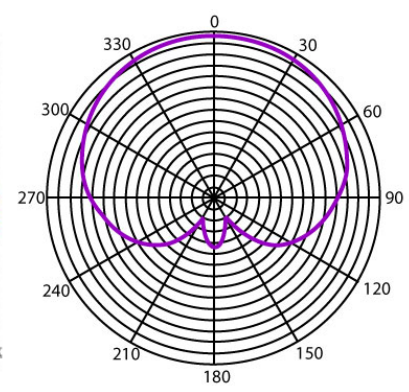
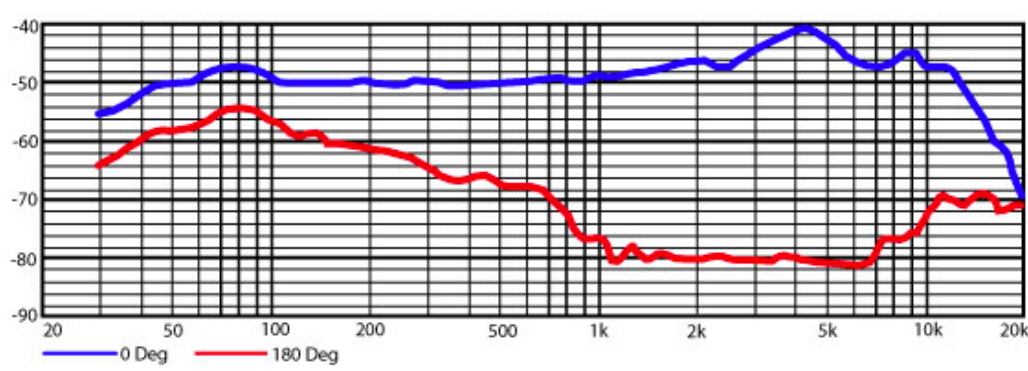

Notes:

- These are the mics we have in the Alan Slaight
- Great low-end response, sounds like a beefier SM7B
- Use it for your podcast to bring out that deep "radio host" richness in your voice

Sennheiser MD 421-II



TYPE	Dynamic
PICKUP	Cardioid
POWER	None
COMMON USES	Toms, Snare, Bass, Vocals
SIMILAR MICS	PR-30

AUTHORIZATION
The Creative School

Frequency Response:

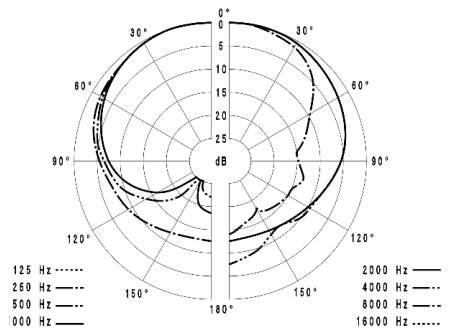
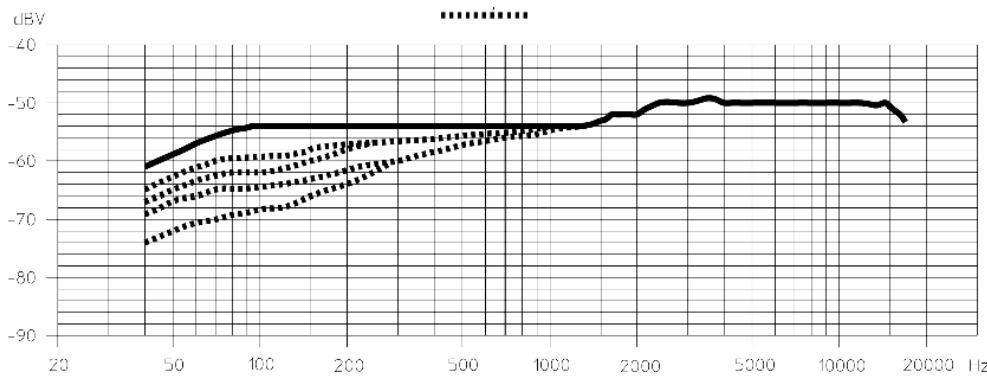

Notes:

- Dial at bottom of mic is for bass roll off, ranges from "Music" (No attenuation) to "Speech" (-6db to everything under 500hz)
- This mic is most commonly used as a drum mic, many find that it works great with vocals, specifically loud male singers of rock, rap, and metal

Shure SM57



TYPE	Dynamic
PICKUP	Cardioid
POWER	None
COMMON USES	Snare, Elec. Guitar, Cymbals
SIMILAR MICS	SM58

AUTHORIZATION
The Creative School

Frequency Response:

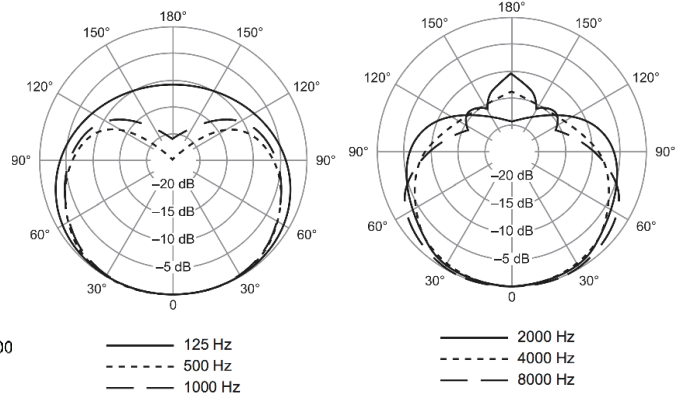
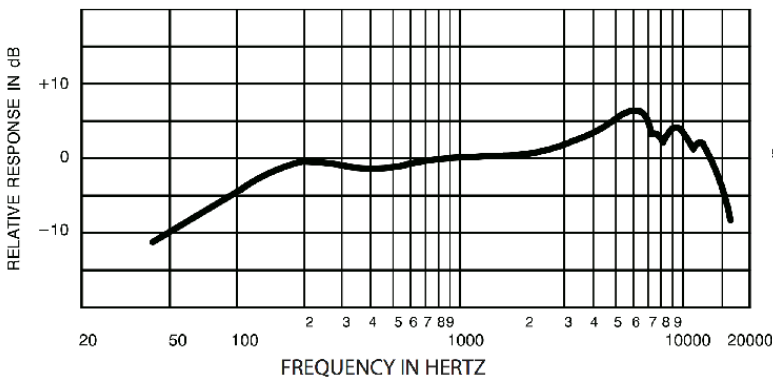

Notes:

- The famous industry standard go-to instrument dynamic mic
- Most snare and electric guitar recordings
- Same microphone capsule as the SM58, but a modified grill for close miking
-

Shure SM7B



TYPE	Dynamic
PICKUP	Cardioid
POWER	None
COMMON USES	Vocals, Podcast, Electric, Guitar, Bass, Horns
SIMILAR MICS	PR 40, MD 421

AUTHORIZATION
RTA

Frequency Response:

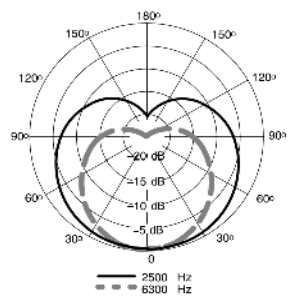
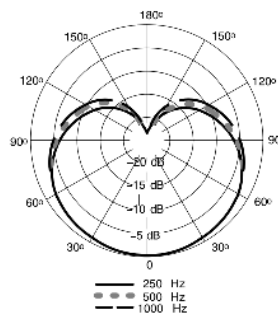
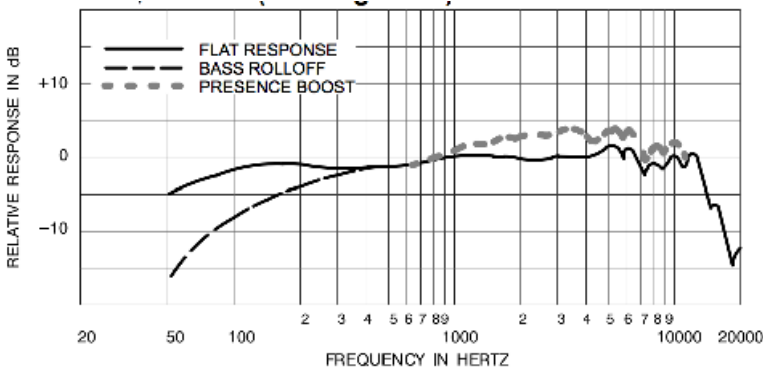

Notes:

- Useful for close-miking instruments in studio where warm and smooth full-frequencies are a must
- Improved version of classic vocal mic used by Michael Jackson and Bob Dylan, still a go-to for contemporary acts such as Brockhampton

Audio-Technica AT8004



TYPE Dynamic - Handheld

PICKUP Omnidirectional

POWER None

COMMON USES Interview, News Gathering, Ambience

SIMILAR MICS RE50N, EV635A

AUTHORIZATION
The Creative School

Frequency Response:

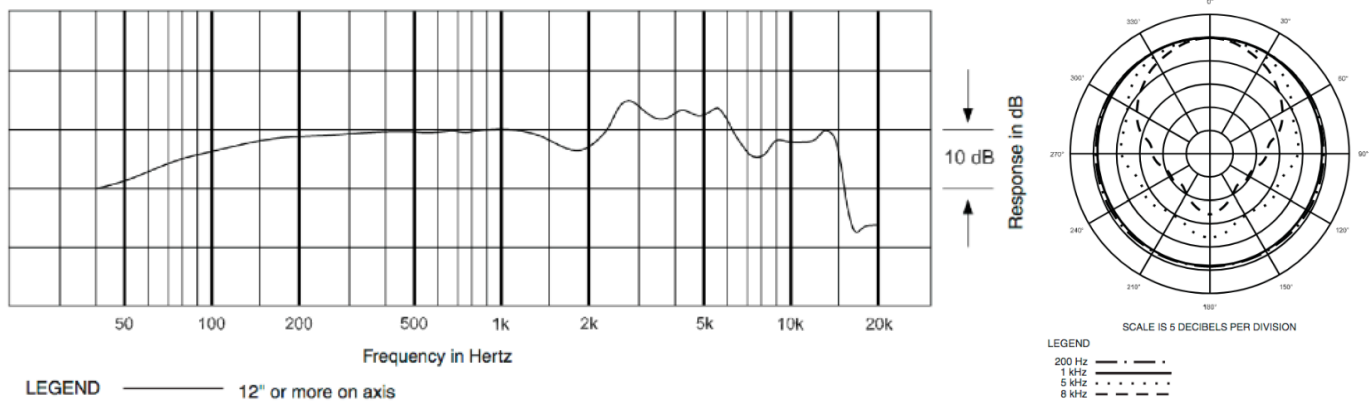

Notes:

- Sounds great for interviews, and is significantly more discreet and lightweight than the MD46
- Internal shock mount to reduce handling noise
- Omnidirectional: picks up sounds equally from all directions

Beyerdynamic TG-X 48



TYPE Dynamic - Handheld

PICKUP Super Cardioid

POWER None

COMMON USES Live Vocals

SIMILAR MICS SM58

AUTHORIZATION
The Creative School

Frequency Response:

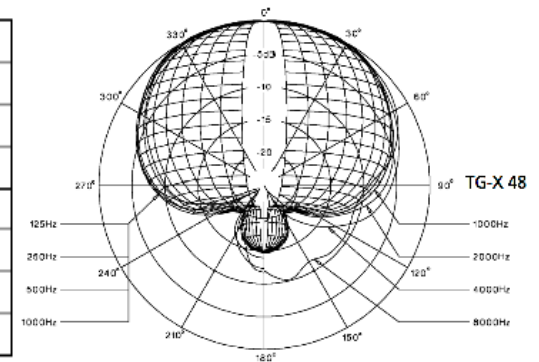
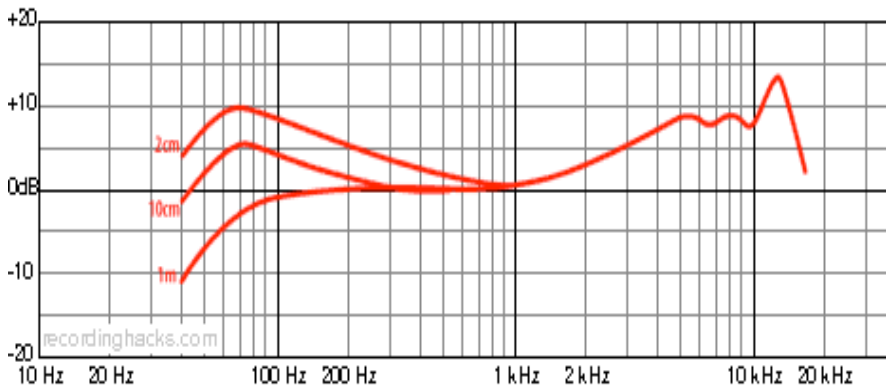

Notes:

- Modelled after the SM58, with the intention of being a higher quality alternative
- Improved built-in wind screen
- Smoother sound, with a tighter off-axis rejection
- "Special soft finish" to make for a more comfortable grip

Electro-Voice EV635A



TYPE Dynamic - Handheld

PICKUP Omnidirectional

POWER None

COMMON USES Interview, Reporting, Electric Guitar, Vocals

SIMILAR MICS RE50N, MD 46

AUTHORIZATION
FCAD

Frequency Response:

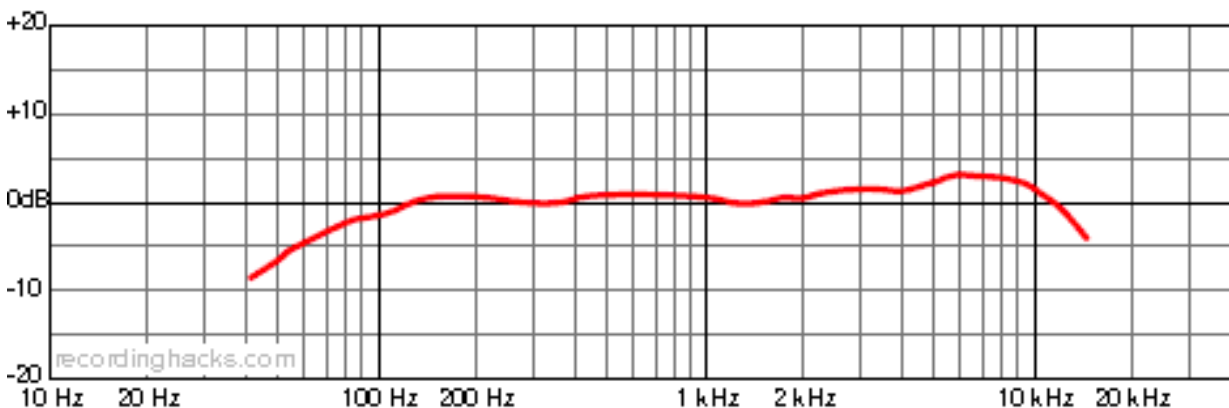

Notes:

- "The best-known news gathering mic in the world"
- Very versatile. Primarily used for journalism but is an effective and unique-sounding mic in music recording.
- The built-in 4 stage pop filter ensures minimal plosives
- Durable design makes it ideal for field recording

Electro-Voice RE50N/D-B



TYPE Dynamic - Handheld

PICKUP Omnidirectional

POWER None

COMMON USES Interview, News Gatherings, Field Production

SIMILAR MICS MD 46, EV 635A

AUTHORIZATION
The Creative School

Frequency Response:

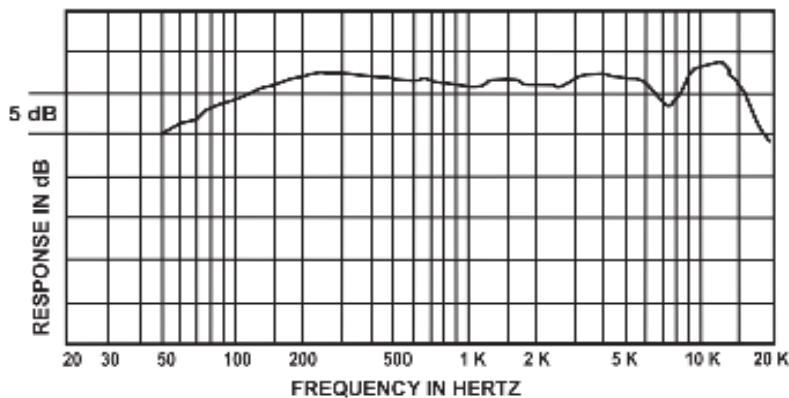

Notes:

- 4 stage pop filter effectively blocks out most pops and plosives
- Omnidirectional: picks up sounds equally from all directions
- Very low handling noise

Sennheiser MD 46



TYPE Dynamic - Handheld

PICKUP Cardioid

POWER None

COMMON USES Reporting, Interview, Field Production

SIMILAR MICS EV RE50N

AUTHORIZATION
JRN

Frequency Response:

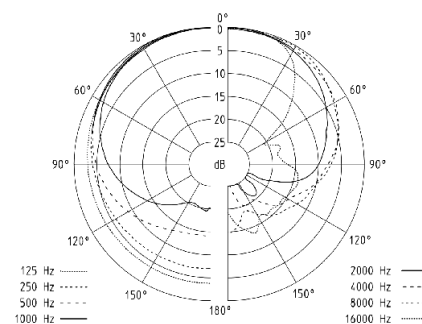
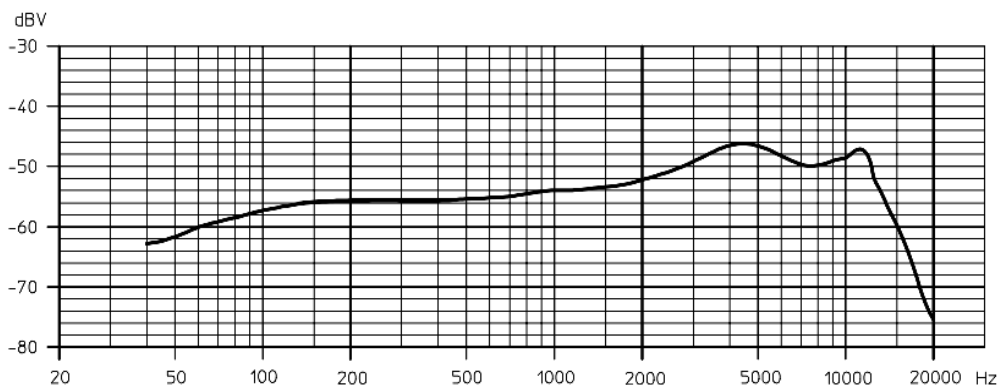

Notes:

- Optimized frequency response enhances speech clarity
- Whereas omnidirectional microphones pick up all sound equally, including background noise, the MD 46 only focuses on where it's being pointed and blocks out everything else

Shure SM58



TYPE Dynamic - Handheld

PICKUP Cardioid

POWER None

COMMON USES Live Vocals

SIMILAR MICS SM57, TG-X 48

AUTHORIZATION
The Creative School

Frequency Response:

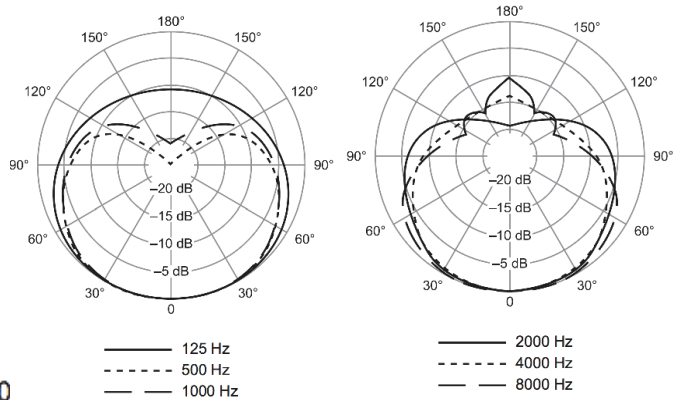
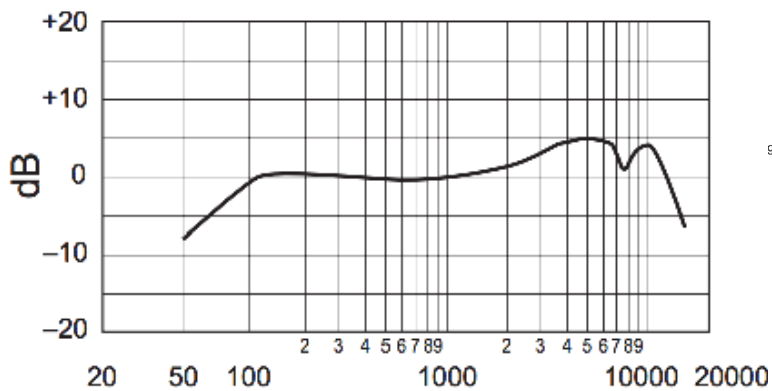

Notes:

- By far the most common mic you will see used for live vocals
- Very close pickup pattern and strong off-axis rejection
- Very durable

Sony F-112



TYPE	Dynamic - Handheld
PICKUP	Omnidirectional
POWER	None
COMMON USES	Interview, News Gathering, Field Production
SIMILAR MICS	RE50N, EV635A

AUTHORIZATION
The Creative School

Frequency Response:

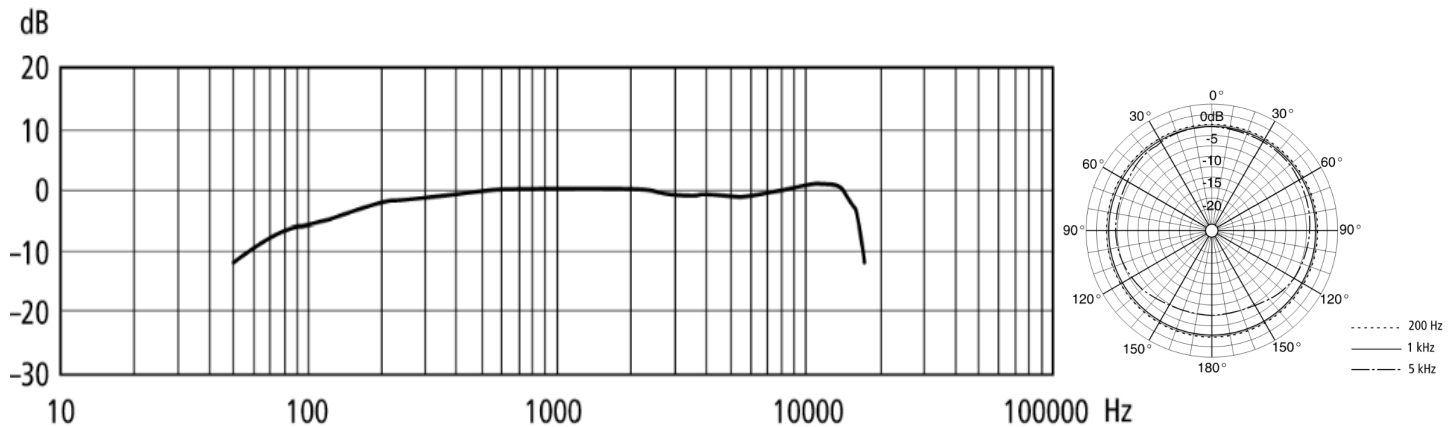

Notes:

- High sensitivity, great for pickup up voices at varying distances and all directions
- Smooth and natural sound reproduction
- Omnidirectional: picks up sounds equally from all directions

Shure Beta 52A



TYPE Dynamic - Kick Drum Mic

PICKUP Supercardioid

POWER None

COMMON USES Kick Drum, Bass

SIMILAR MICS AKG D112, RE20

AUTHORIZATION
The Creative School

Frequency Response:

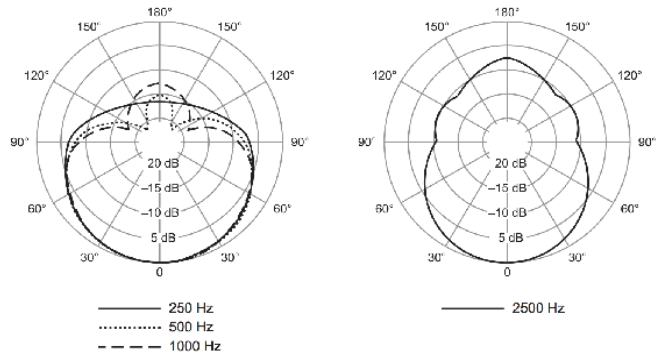
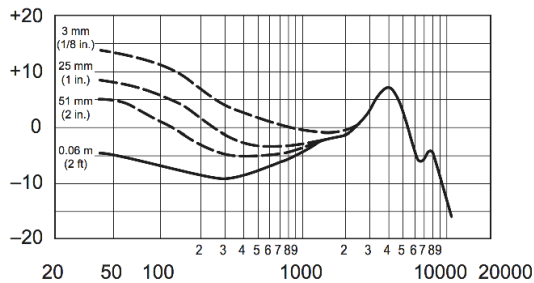

Notes:

- ONLY AVAILABLE IN SHURE DRUM MIC KIT
- Very little bleed makes it great for both live and studio use
- Joe Barresi's favorite kick mic (Nine Inch Nails, Weezer, Kelly Clarkson, Every Time I Die)

AKG D112



TYPE Dynamic - Kick Drum Mic

PICKUP Cardioid

POWER None

COMMON USES Kick Drum, Bass, Floor Tom

SIMILAR MICS BETA 52A, RE20

AUTHORIZATION
RTA

Frequency Response:

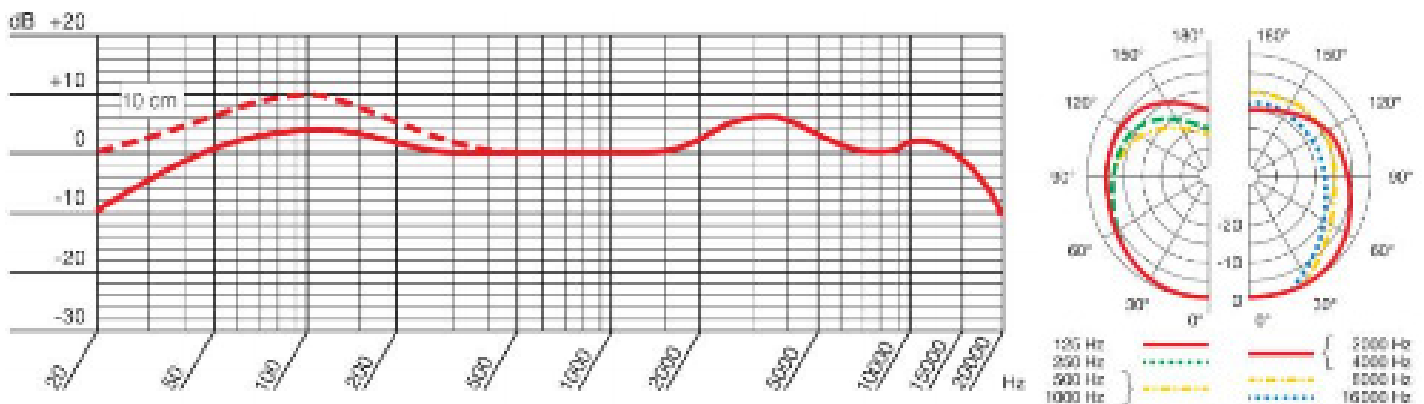

Notes:

- One of the most popular kick mics in the industry
- Modelled after the classic D12 (the world's first dynamic cardioid microphone)
- Endorsed by producers such as Steve Albini (Nirvana), Steve Churchyard (Joni Mitchell), Bob Clearmountain (Bruce Springsteen)

AKG D200E



TYPE

Dynamic - Two Way

PICKUP

Cardioid

POWER

None

COMMON USES

Drums, Electric Guitar, Piano

SIMILAR MICS

SM57, D2020E

AUTHORIZATION
The Creative School

Frequency Response:

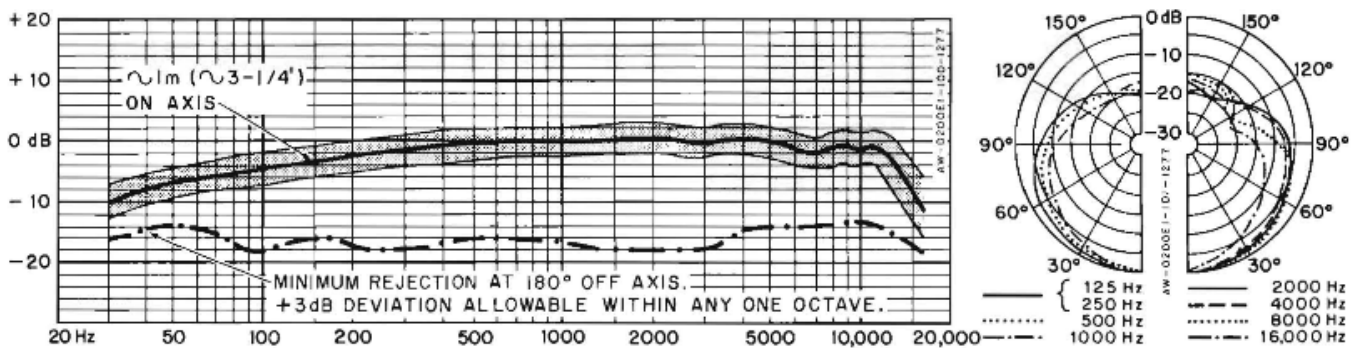

Notes:

- Bright, vintage sound
- Good for experimenting. Try it on anything!
- Unique two-way capsule design means it can get as close to a sound source as possible without exhibiting proximity effect

AKG D202E



TYPE Dynamic - Two Way Dynamic

PICKUP Cardioid

POWER None

COMMON USES Snare, Toms, Vocals

SIMILAR MICS D200E, D224E

AUTHORIZATION
The Creative School

Frequency Response:

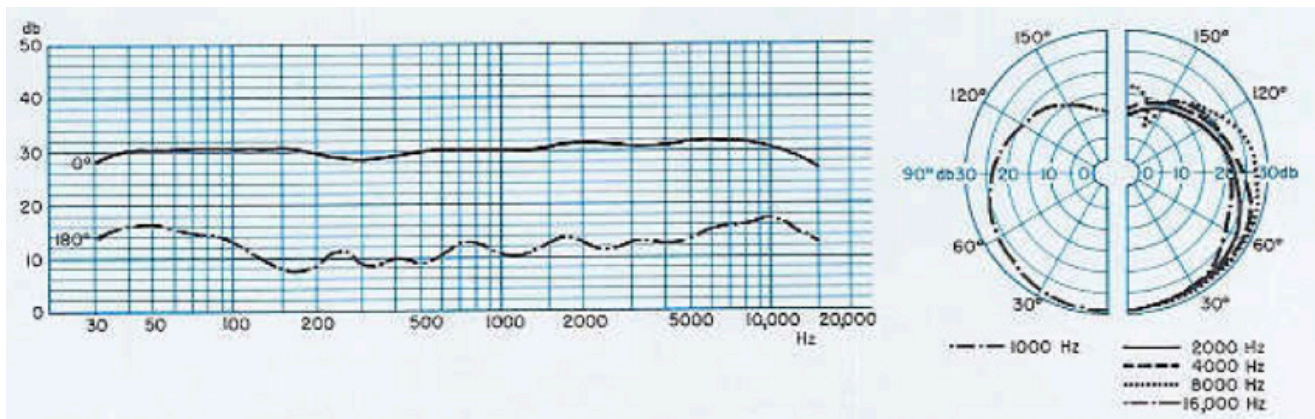

Notes:

- Dual capsule design, sounds like a condenser with the SPL capabilities of a dynamic
- Vintage sound with a wide frequency range (30hz-18khz)
- Popular in 70s heavy rock recording

AKG D224E



TYPE Dynamic - Two Way

PICKUP Cardioid

POWER None

COMMON USES Electric Guitar, Acoustic, Guitar, Snare

SIMILAR MICS D202E, D200E

AUTHORIZATION
RTA

Frequency Response:

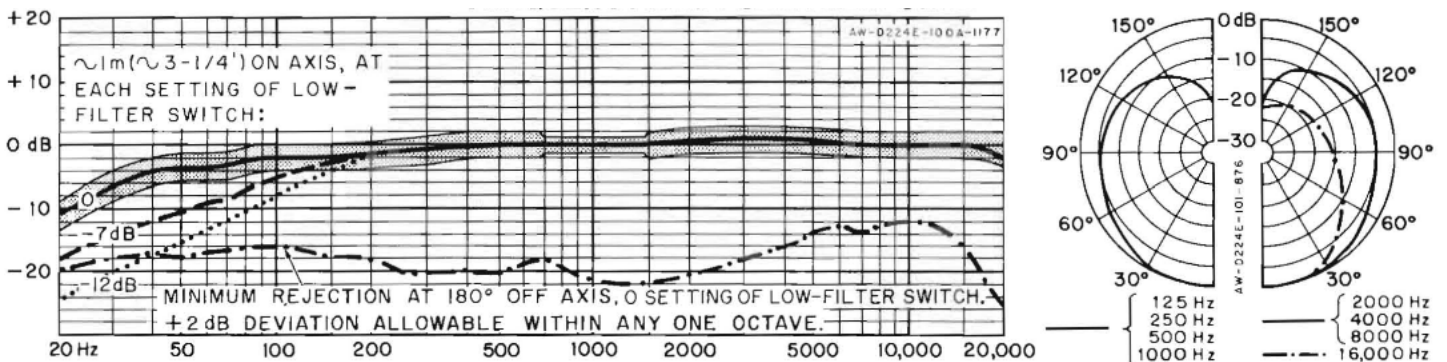

Notes:

- Widest frequency range in the product series (20hz-20khz)
- Very detailed sound with great off-axis rejection
- Sounds great on practically anything

Apex 420



TYPE Large Diaphragm Condenser

PICKUP Omnidirectional, Cardioid

POWER 48v

COMMON USES Vocals, Drum Room, Acoustic Guitar

SIMILAR MICS NT2, MXL 700

AUTHORIZATION
The Creative School

Frequency Response:

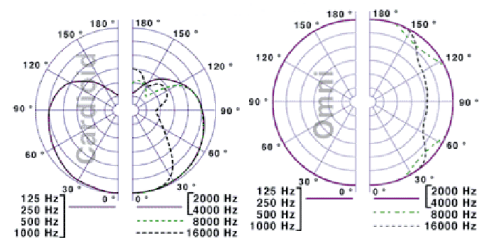
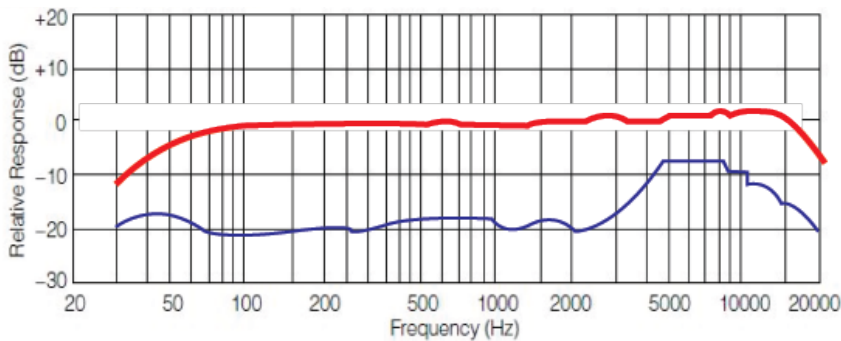

Notes:

- Features a low end roll off switch (-6db below 100hz)
- Can handle up to 130dB SPL without distortion
- The front of the mic is the side with the switches

Audio Technica AT4050



TYPE Large Diaphragm Condenser

PICKUP Cardioid, Omni, Figure 8

POWER 48v

COMMON USES Acoustic Guitar, VO, Kick, Room, Overhead

SIMILAR MICS C414, NT2A

AUTHORIZATION
RTA

Frequency Response:

Cardioid

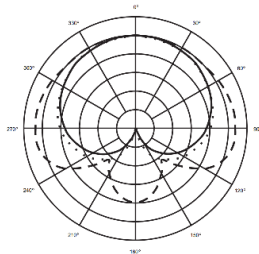
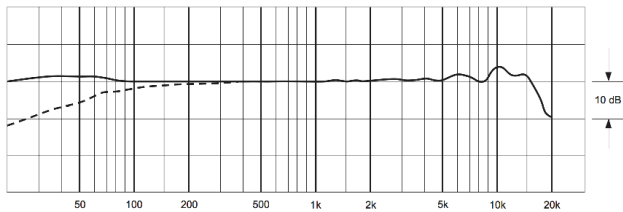

Omnidirectional

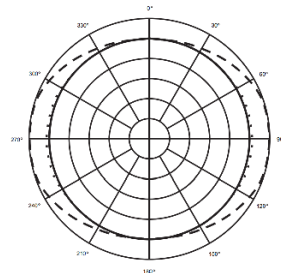
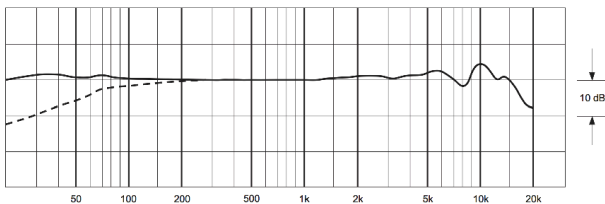

Bidirectional

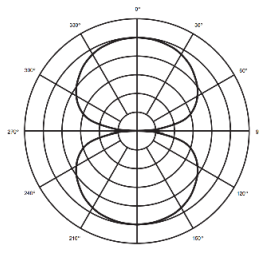
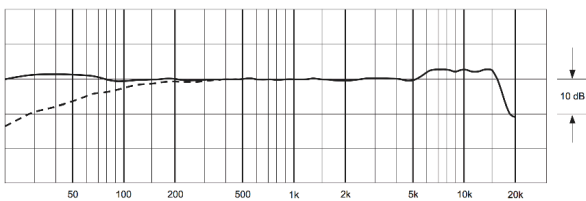

Blue Baby Bottle



TYPE Large Diaphragm Condenser

PICKUP Small Cardioid

POWER 48v

COMMON USES Vocals/ VO, Drums, Acoustic, Guitar, Bass

SIMILAR MICS TLM 103, C414

AUTHORIZATION
RTA

Frequency Response:

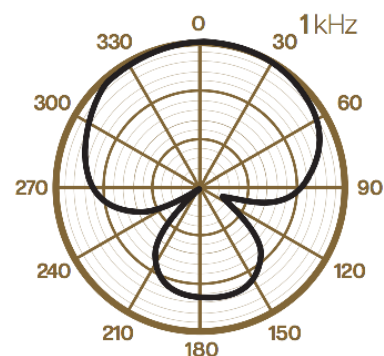
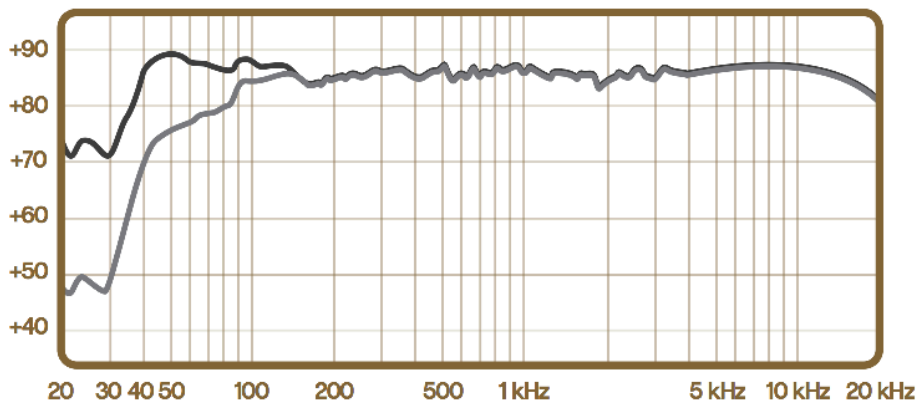

Notes:

- High output and low noise, reproduces a clean sound that can be heavily manipulated/affected and still sound nice
- Very crisp, high-presence sound

Blue Blueberry



Frequency Response:

TYPE Large Diaphragm Condenser

PICKUP Cardioid

POWER 48v

COMMON USES Acoustic Guitar, VO, Kick, Room, Overhead

SIMILAR MICS Blue Baby Bottle, TLM 103

AUTHORIZATION
RTA

Notes:

- Multi-purpose mic-ideal for lead vocal, acoustic guitar, and backing vocal
- Intimate sound- tight lows and mids, countoured top end for superior airy presence in the highs

KEL HM-7U



TYPE Large Diaphragm Condenser

PICKUP Super Cardioid

POWER 48v

COMMON USES Vocals/ VO, Kick

SIMILAR MICS TLM 49

AUTHORIZATION
The Creative School

Frequency Response:

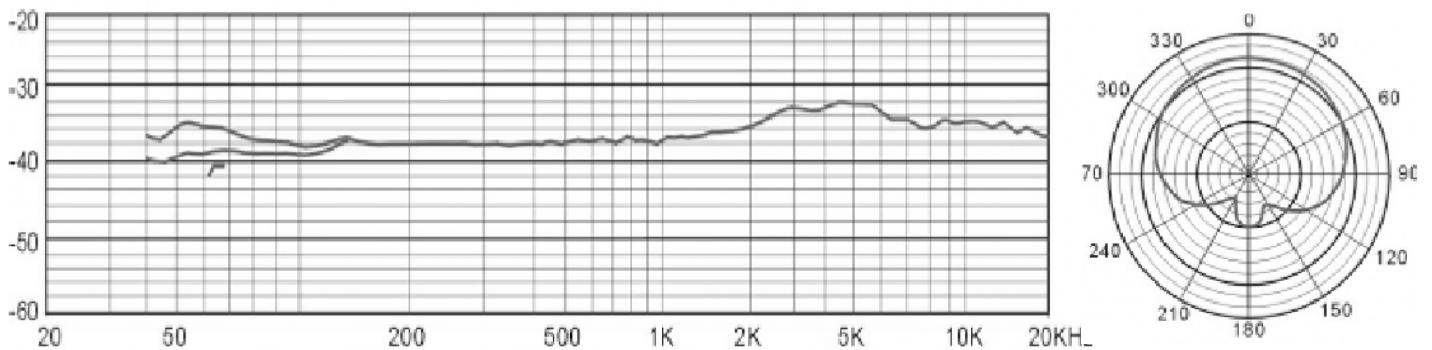

Notes:

- Designed as a clone of the historic U47 (Vocal mic used by the Beatles, Sinatra, etc)
- Front of mic is the side with the glowing light

MXL 770



TYPE Large Diaphragm Condenser

PICKUP Small Cardioid

POWER 48v

COMMON USES Vocals, Piano, Strings, Cymbals

SIMILAR MICS NT1, C3000

AUTHORIZATION
The Creative School

Frequency Response:

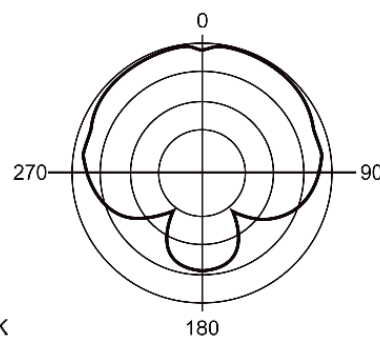
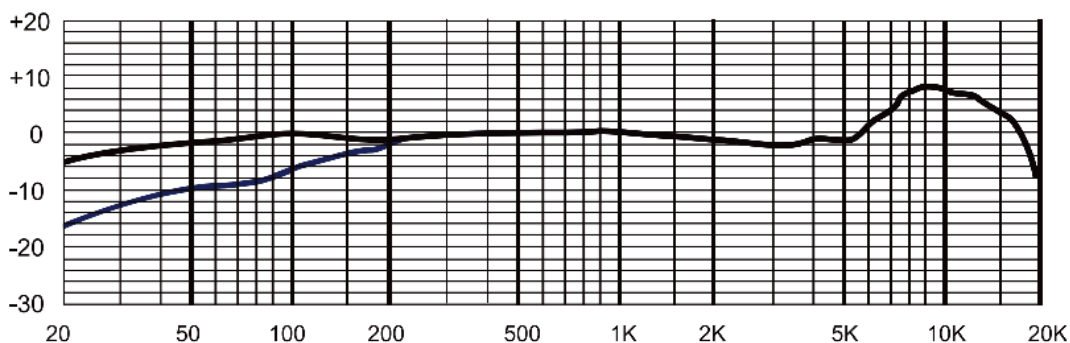

Notes:

- Multipurpose condenser with a bright sound
- Particularly suited for rap vocals because of the solid bass response and bright top end
- Bass roll-off and -10db pad switches

Neumann TLM 103



TYPE Large Diaphragm Condenser

PICKUP Cardioid

POWER 48v

COMMON USES Vocals, VO, Drum Room, Strings, Sound Design

SIMILAR MICS Baby Bottle, C414

AUTHORIZATION
The Creative School

Frequency Response:

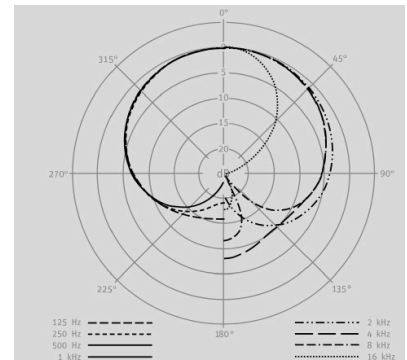
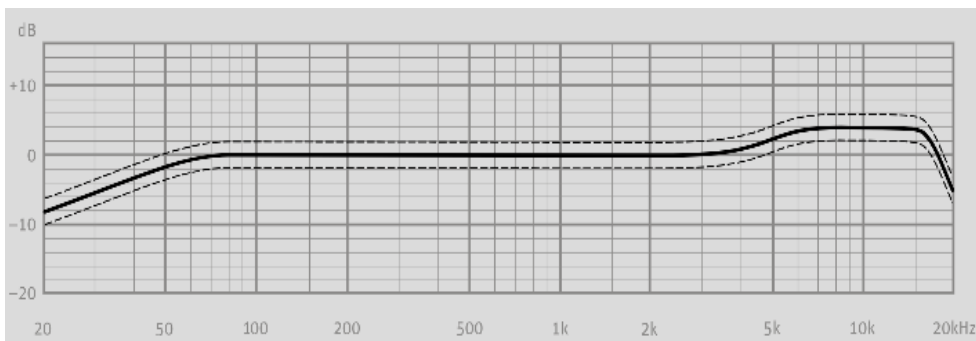

Notes:

- A faithful modernized version of the Neumann U87 ("The world's most famous vocal mic", used by The Beatles, Amy Winehouse, Stevie Wonder)
- Extremely low noise means dramatic EQ or compression can be applied and still sound good

Neumann TLM 49



TYPE Large Diaphragm Condenser

PICKUP Cardioid

POWER 48v

COMMON USES Vocals, VO, Acoustic Guitar, Bass, Foley

SIMILAR MICS KEL HM-7U

AUTHORIZATION
RTA

Frequency Response:

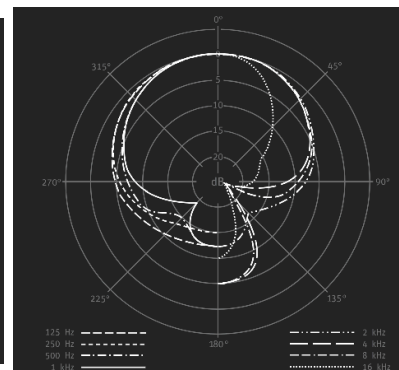
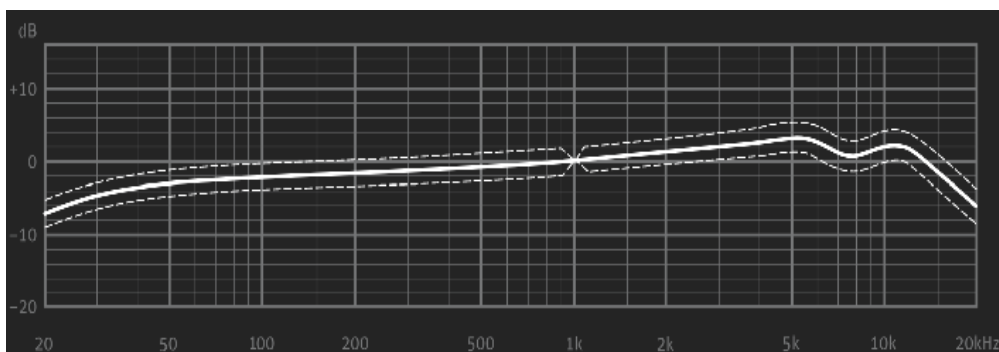

Notes:

- Emulates the smooth, vintage tube sound of the U47 (Frank Sinatra, The Beatles, Adele) and M49 (1950s jazz standard microphone)
- Large, open headgrille gives vocals a very spacious sound

Rode NT2000



TYPE Large Diaphragm Condenser

PICKUP Cardioid, Omni, Figure 8

POWER 48v

COMMON USES Vocal, Any Instrument

SIMILAR MICS NT2A

AUTHORIZATION
The Creative School

Frequency Response:

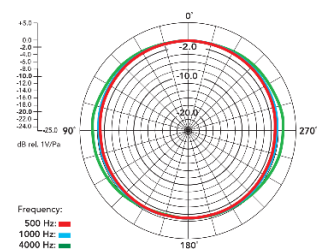
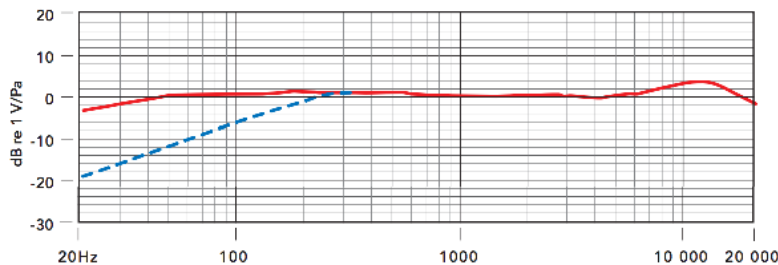
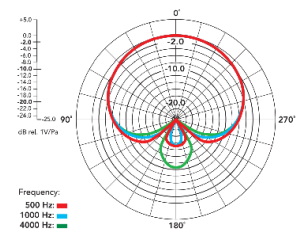
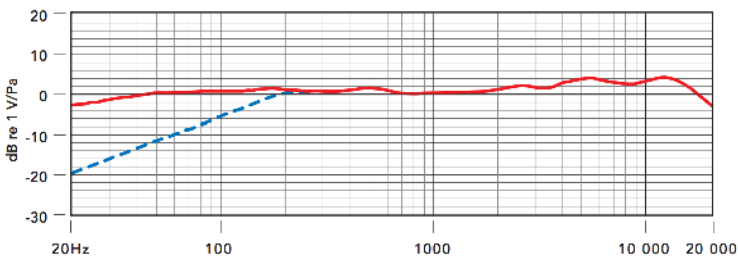

Notes:

- Known as a solid all-rounder mic, will reliably sound good on any instrument you put it in front of
- Same frequency charts as NT2-A, but in practice has a very different sound

Rode NT1



TYPE Large Diaphragm Condenser

PICKUP Cardioid

POWER 48v

COMMON USES Piano, Cymbals, VO, Foley

SIMILAR MICS MXL 700, NT2A

AUTHORIZATION
The Creative School

Frequency Response:

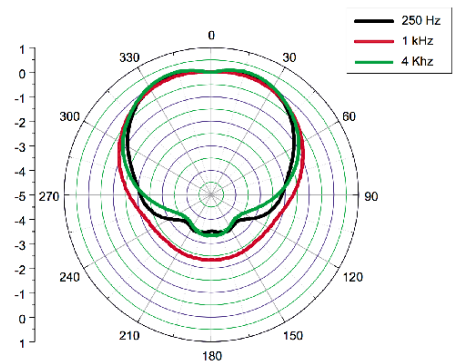
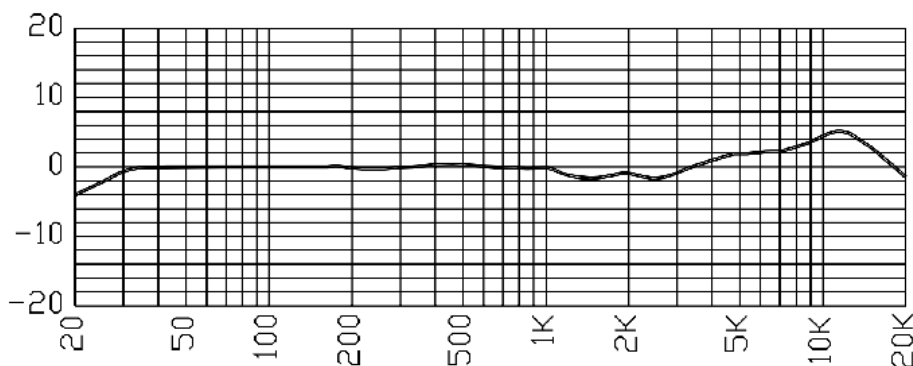

Notes:

- This is the original version of the much-revised NT1 from the 90s
- Usually described as having a "gritty" sound

Rode NT2-A



TYPE Large Diaphragm Condenser

PICKUP Cardioid, Omni, Figure 8

POWER 48v

COMMON USES VO, Piano, Drum Overhead, Acoustic Guitar

SIMILAR MICS NT2000

AUTHORIZATION
The Creative School

Frequency Response:

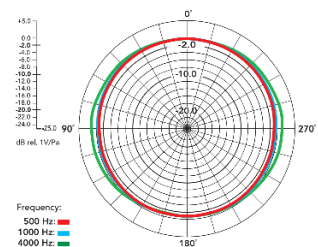
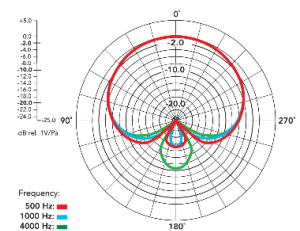
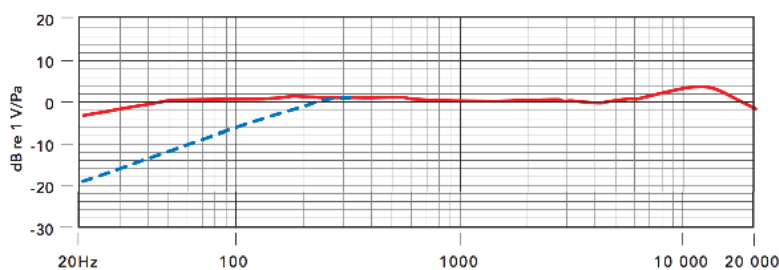
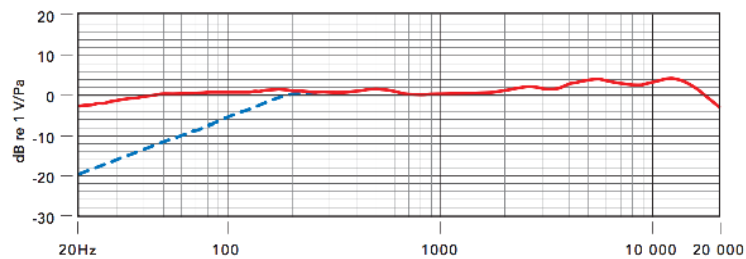

Notes:

- One of the lowest noise floors on the market
- A "gritty" sound when compared to the smooth-sounding NT2000

AKG C3000



TYPE Large Diaphragm Condenser, Dual Capsule

PICKUP Cardioid, Super Cardioid

POWER 48v

COMMON USES Vocals, Electric/Acoustic, Guitar, Drum Room

SIMILAR MICS MXL 700, NT2, C414

AUTHORIZATION RTA

Frequency Response:

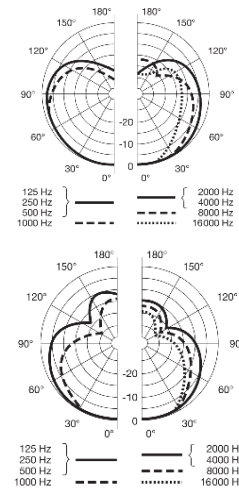
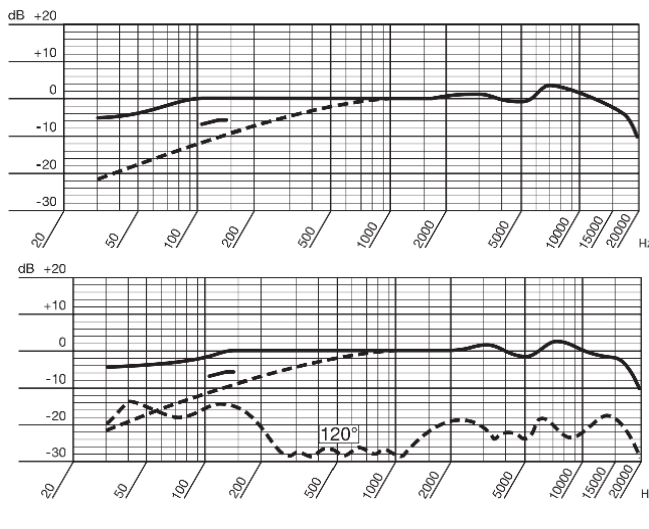

Notes:

- Created as an affordable alternative to the C414, similar capsule/sound
- "Classic AKG vocal mic sound"
- Feedback-resistant and low handling noise makes it great for live use

Apex 215



TYPE	Dual Ribbon
PICKUP	Bidirectional
POWER	None (Do not send phantom power)
COMMON USES	Guitar, Strings, Piano
SIMILAR MICS	N/A

AUTHORIZATION
The Creative School

Frequency Response:

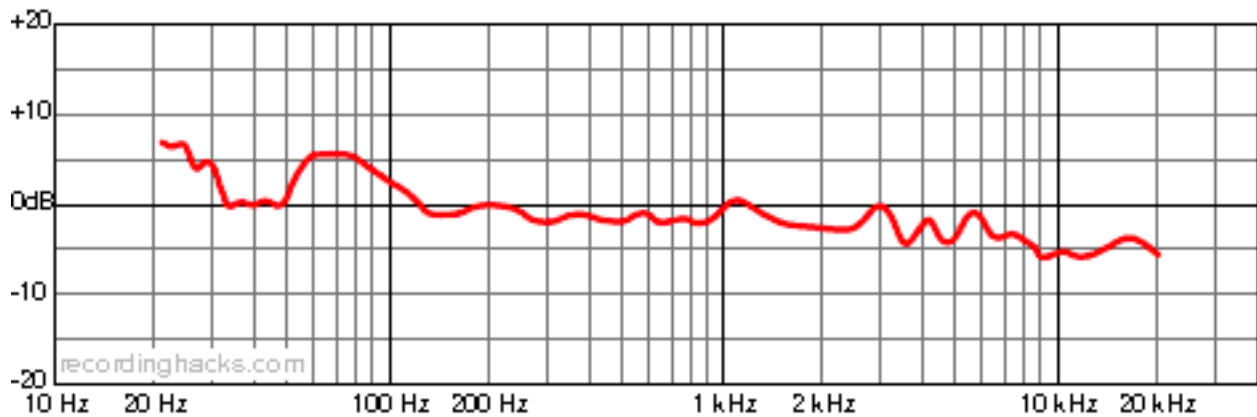

Notes:

- Dual-ribbon design makes for higher sensitivity/more detailed recordings than single-ribbon designs
- Can handle SPLs up to 137dB, so don't be afraid to use as drum overheads or amp mics. Very warm, bass-rich sound

Coles 4038



TYPE	Ribbon
PICKUP	Figure 8
POWER	None (Do not send phantom power)
COMMON USES	Mono Drum Overhead/Room, Horns, Acoustic Guitar
SIMILAR MICS	N/A

AUTHORIZATION
The Creative School

Frequency Response:

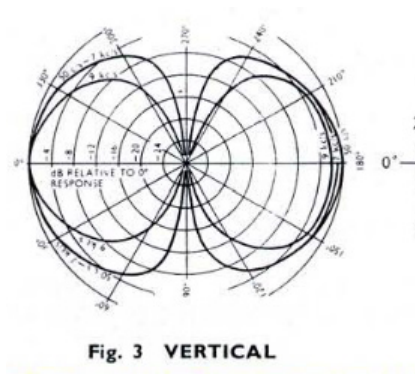
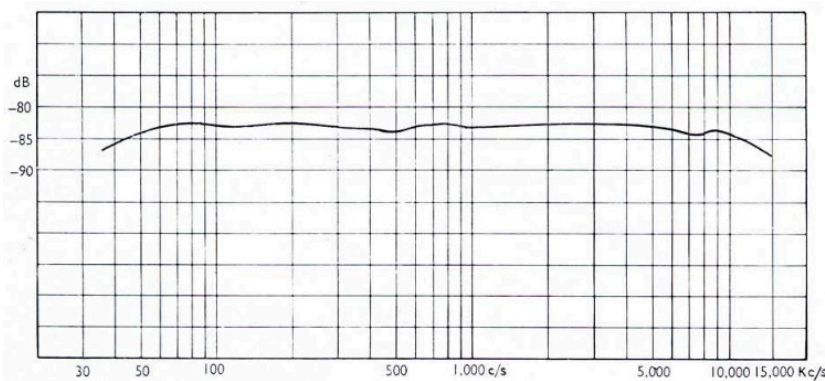

Notes:

- Considered one of the smoothest sounding mics around
- Drum overhead mic of choice for The Beatles and Led Zeppelin
- Handle with great care and caution. Use a pop filter with vocals, and keep static-resistant cover on it when not in use

Panasonic AG MC-200



TYPE	Shotgun - Mini Condenser
PICKUP	Supercardioid
POWER	48v (XLR Phantom Power Only)
COMMON USES	Used with AC90 Camera
SIMILAR MICS	Panasonic AG MC-100

AUTHORIZATION
The Creative School

Frequency Response:

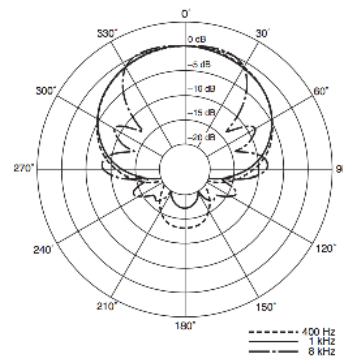
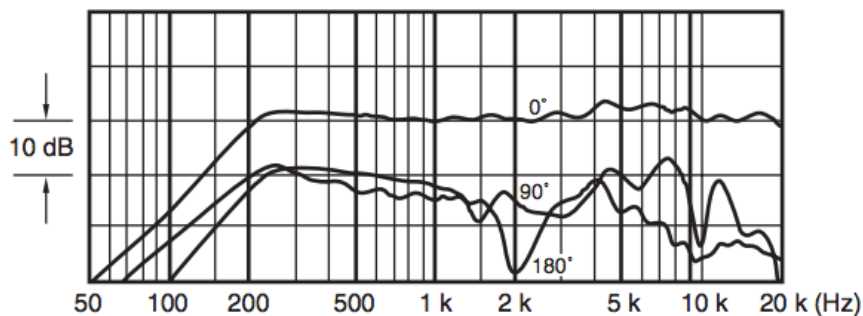

Notes:

- Does not take batteries, must be plugged into an XLR jack to receive phantom power (XLR to Mini converters will not work)
- Intended for use with Panasonic AC90 Camera

Sony C-76



TYPE	Shotgun - Giant
PICKUP	Superunidirectional
POWER	48v or 9V Battery
COMMON USES	Locational Sound, Jousting
SIMILAR MICS	N/A

AUTHORIZATION
The Creative School

Frequency Response:

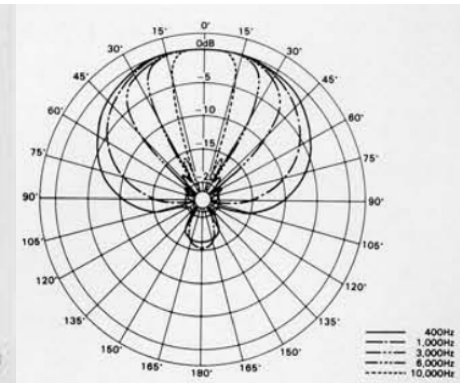
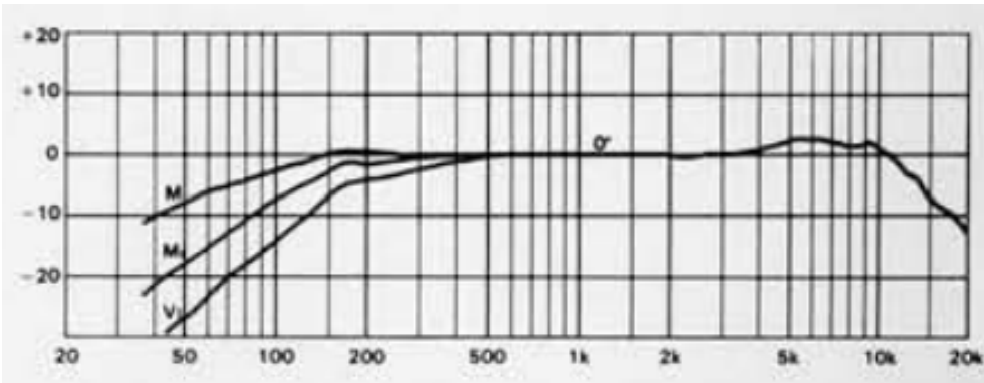

Notes:

- Over 2 feet long
- Very directional, making it very useful for capturing clear audio in noisy environments
- 3 stage of low-end roll off: M, M1, and V1

Sennheiser Mke 600



TYPE Shotgun - Condenser

PICKUP Supercardioid

POWER 48v or 1 AA Battery

COMMON USES Location Sound, Field Recording

SIMILAR MICS AT 897, ME66

AUTHORIZATION
The Creative School

Frequency Response:

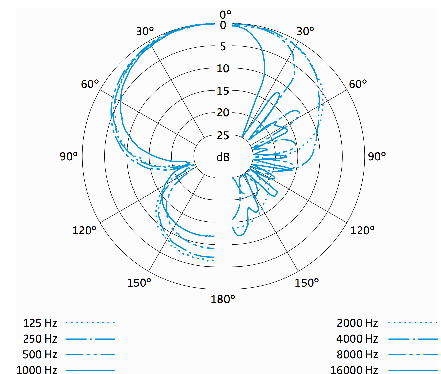
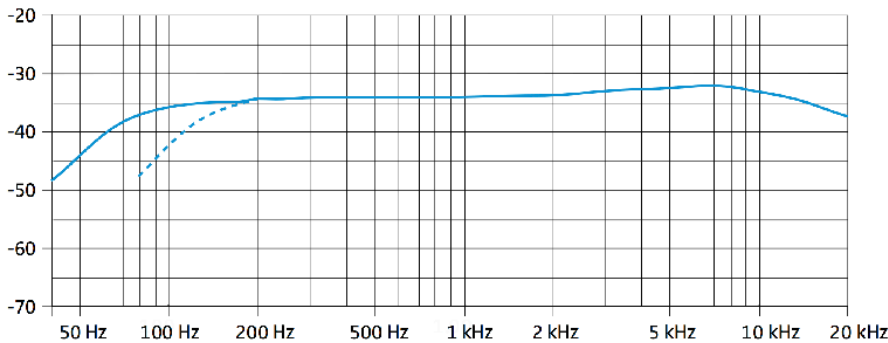

Notes:

- LED Above BATT switch only turns on when battery is low, it is not an indicator of whether or not the microphone is actually turned on
- Bass roll-off filter (150hz and below) switch to reduce handling noise

Audio Technica AT897



TYPE Shotgun - Condenser

PICKUP Supercardioid

POWER 48v or 1 AA Battery

COMMON USES Locational Sound, Field Recording

SIMILAR MICS MKE600, ME66

AUTHORIZATION
The Creative School

Frequency Response:

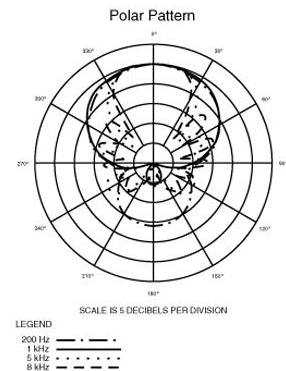
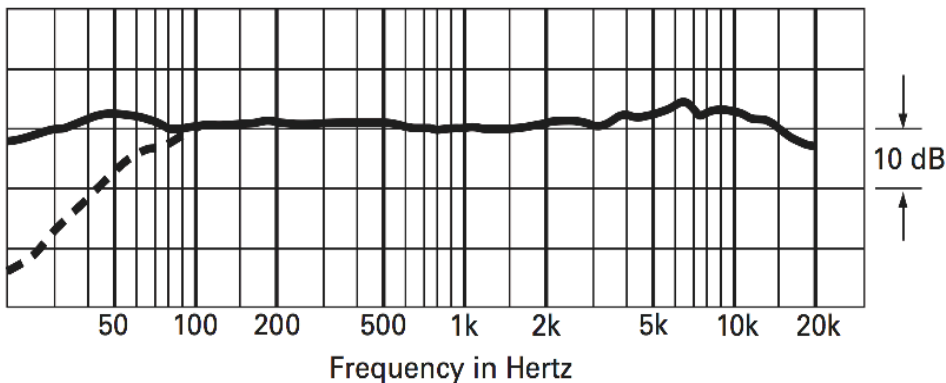

Notes:

- Bass roll-off filter switch (80hz and below) to reduce handling noise. Use a pin or thin screwdriver to engage
- Unscrew bottom half of microphone to insert battery

Sennheiser ME66



TYPE Shotgun - Condenser

PICKUP Supercardioid

POWER 48v or 1 AA Battery

COMMON USES Location Sound, Field Recording

SIMILAR MICS AT 897, MKE 600

AUTHORIZATION
The Creative School

Frequency Response:

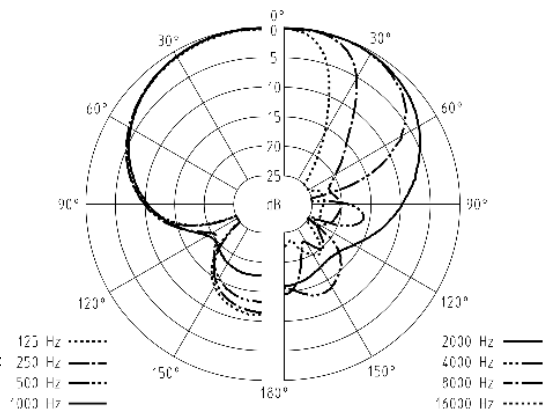
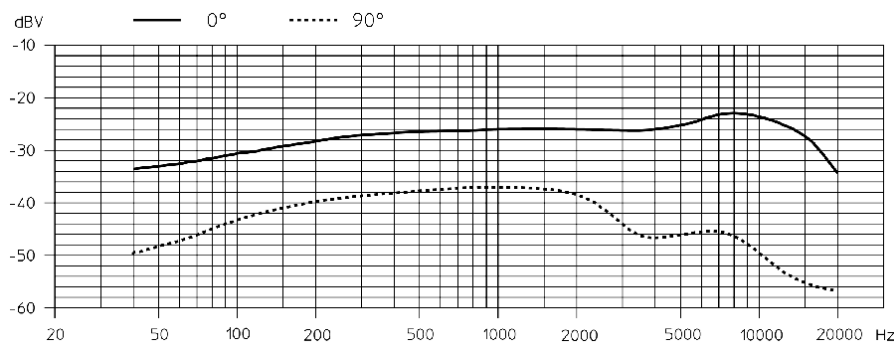

Notes:

- High 125 dB maximum SPL provides distortion-free recording
- Switchable bass roll-off filter (400hz and below), use a pin or thin screwdriver to engage
- LED Above BATT switch only turns on when battery is low

Rode NTG2



TYPE Shotgun - Condenser

PICKUP Supercardioid

POWER 48v or 1 AA Battery

COMMON USES Locational Sound, Field Recording

SIMILAR MICS MKE600, ME66

AUTHORIZATION
The Creative School

Frequency Response:

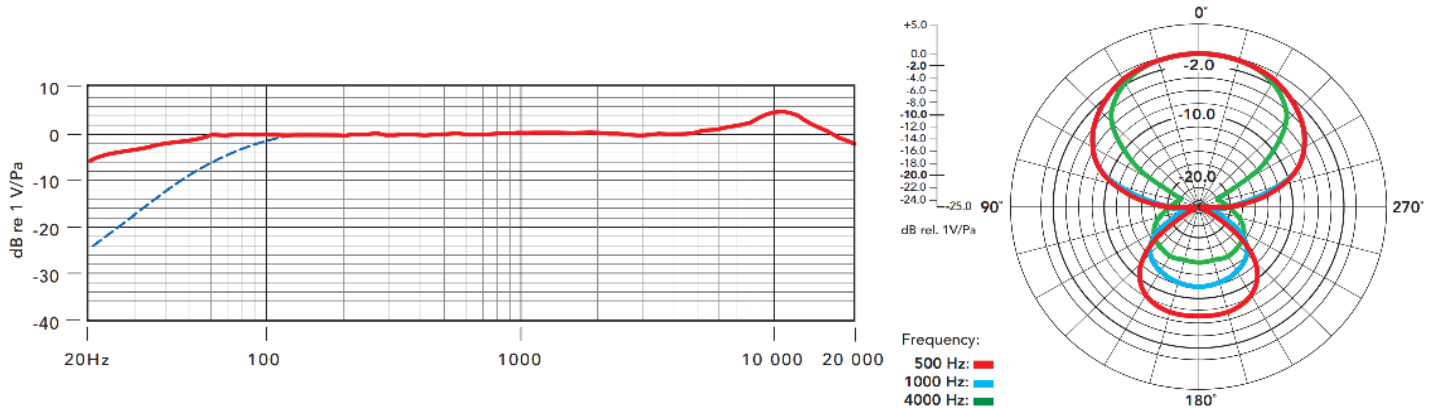

Notes:

- Great for indoor use, effectively eliminates room characteristics for an isolated sound
- Switchable bass roll-off filter (80hz and below), use a pin or thin screwdriver to engage

Earthworks SR30 Pair



TYPE Small Diaphragm Condenser

PICKUP Cardioid

POWER 48v

COMMON USES Drum Overheads, Piano, Sound Design, Foley

SIMILAR MICS NT5

AUTHORIZATION
The Creative School

Frequency Response:

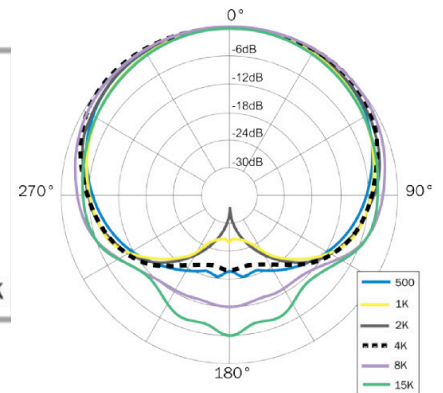
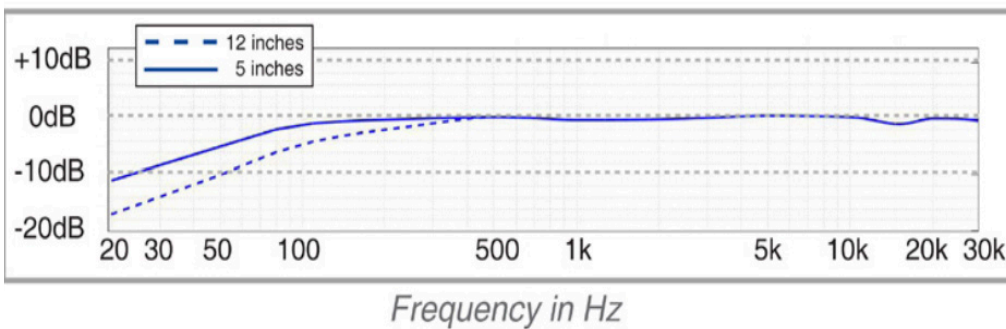

Notes:

- Extended Frequency Range (5hz-30khz)
- Because of its very flat frequency response and near perfect cardioid pickup pattern, the SR30 captures an incredibly "objective" sound

Apex 170



TYPE	Small Diaphragm Pencil Condenser
PICKUP	Cardioid
POWER	48v or Battery
COMMON USES	Live Drums, String, Brass
SIMILAR MICS	N/A

AUTHORIZATION
The Creative School

Notes:

- Condenser with a tight pickup pattern and good off-axis sound rejection
- Frequency range from 80hz to 15khz
- Mysterious. Not a lot of information online. Try it and see

Rode NT5



TYPE	Small Diaphragm Pencil Condenser
PICKUP	Cardioid
POWER	48v
COMMON USES	Drum Overheads, Acoustic Guitar, Indoor Dialogue, Strings
SIMILAR MICS	NT4

AUTHORIZATION
RTA

Frequency Response:

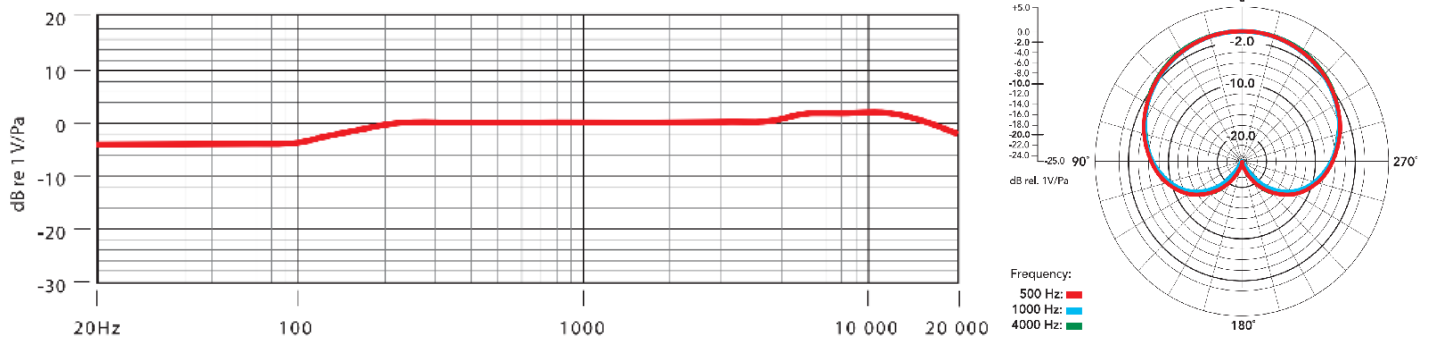

Notes:

- Uses the same mic capsules as the NT4
- Bootsy Collins's favourite mic for acoustic guitar, strings, and room
- Comes as a matched pair, but are excellent for individual use as well

Schoeps CMC-5U w/ MK 4 Capsule



TYPE	Small Diaphragm Pencil Condenser
PICKUP	Cardioid
POWER	48v or Battery
COMMON USES	Cymbals, Strings, Woodwinds, Foley
SIMILAR MICS	NT5

AUTHORIZATION
RTA

Frequency Response:

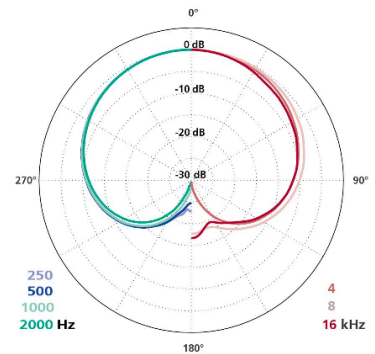
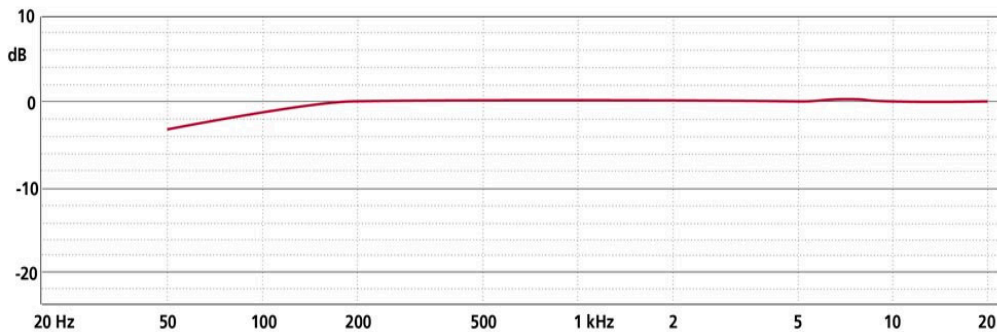

Notes:

- Has a unique "modular" design that allows you to swap out different capsules for different purposes and sounds
- The MK 4 capsule is used for a totally flat, transparent sound - a perfect jumping-off point for EQ and "colouring" the signal.

Audio Technica AT8022



TYPE	Stereo Small Diaphragm Condenser
PICKUP	X/Y Stereo Cardioid
POWER	48v or Battery
COMMON USES	Field Recording
SIMILAR MICS	NT4, S502

AUTHORIZATION
RTA

Frequency Response:

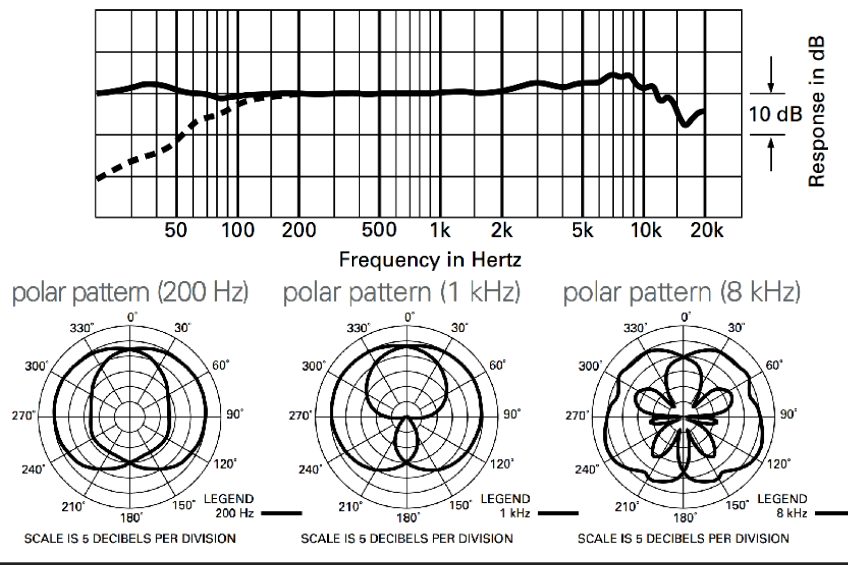

Notes:

- Top-Address
- Ideal for mounting on top of cameras for quick and easy stereo sound

Rode NT4



TYPE	Stereo Small Diaphragm Condenser
PICKUP	X/Y Stereo Cardioid
POWER	48v or Battery
COMMON USES	Drum Overhead, Piano, SFX, Field Recording
SIMILAR MICS	NT5
AUTHORIZATION RTA	

Frequency Response:

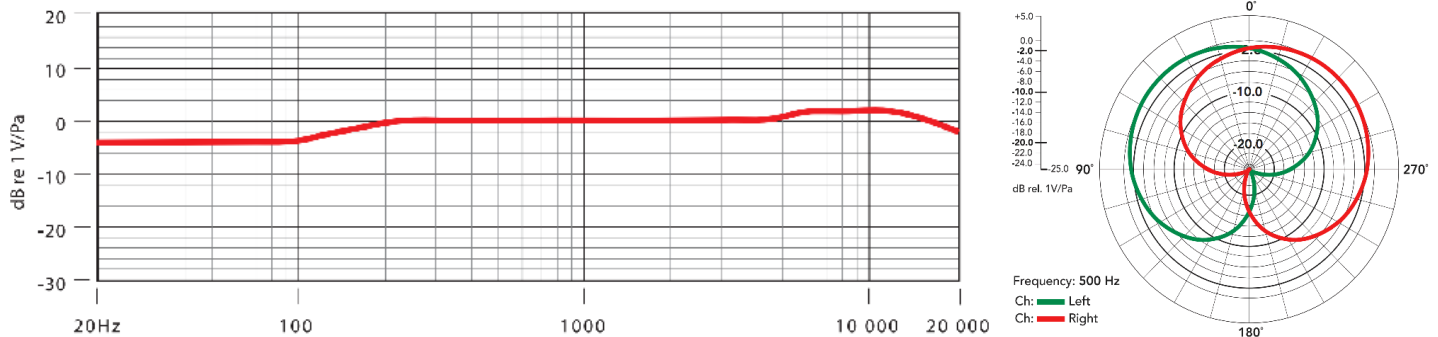

Notes:

- Uses the same mic capsules as the NT4, but fixed at a perfect XY alignment
- Custom 5-pin XLR to dual 3-pin XLR output
- Switch on top controls whether it is powered by phantom power or battery

Superlux S502



TYPE

Stereo Small Diaphragm
Condenser

PICKUP

Fixed ORTF/Cardioid

POWER

48v

**COMMON
USES**

Choir, Orchestra, Field
Recording, Drum Room

**SIMILAR
MICS**

N/A

**AUTHORIZATION
RTA**

Frequency Response:

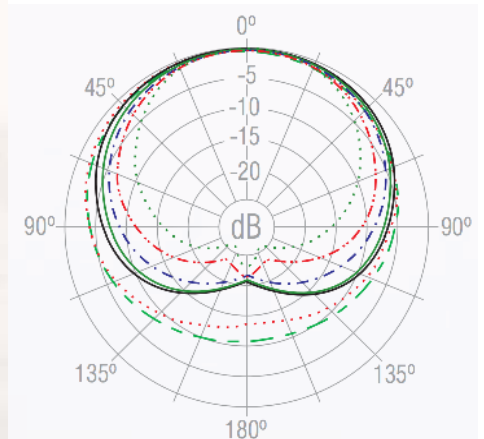
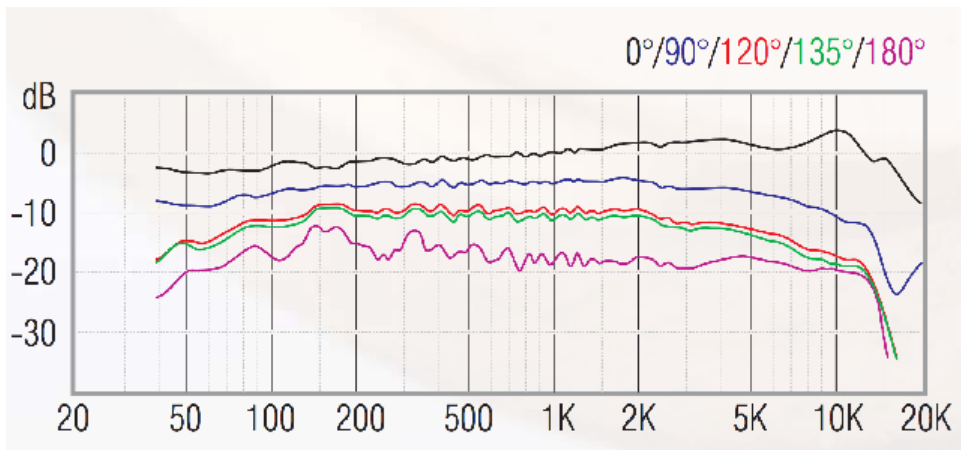

Notes:

- ORTF positioning technique closely reproduces the pickup of human hearing
- Comes with 5-pin XLR splitter, requires 2 input channels for stereo recording
- Should be placed at least 1 meter from sound source for best results

CAD U7



TYPE USB Boundary Mic

PICKUP Omnidirectional

POWER USB

COMMON USES Meetings, Presentations, Interviews

SIMILAR MICS Blue Snowball

AUTHORIZATION
The Creative School

MXL uCHAT



TYPE USB Boundary Mic

PICKUP Half Cardioid

POWER USB

COMMON USES VOIP Calling, Web Conferencing

SIMILAR MICS CAD U7

AUTHORIZATION
The Creative School

Blue Snowball



TYPE USB Condenser Mic

PICKUP Cardioid, Omnidirectional

POWER USB

COMMON USES Voiceover, Podcast, Livestream

SIMILAR MICS Blue Nessie

AUTHORIZATION
The Creative School

Frequency Response:

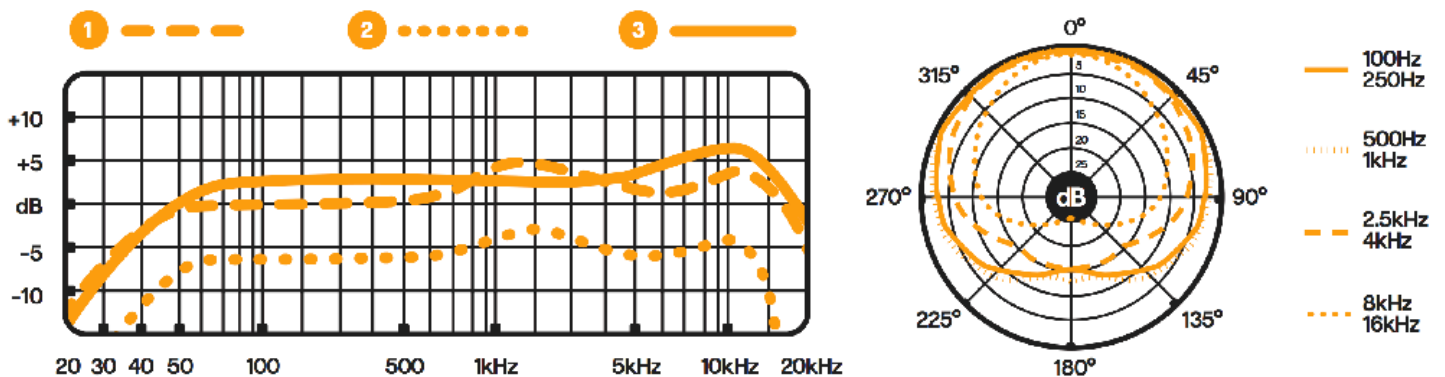

Notes:

- Simple plug n' play design. No drivers or setup required
- 10db pad switch for capturing loud sound sources without distortion
- Switch on the back changes pickup patterns from "1" (Cardioid), "2" (Omnidirectional), and "3" (Cardioid with -10db pad)

Blue Nessie



TYPE	USB Condenser Mic
PICKUP	Cardioid
POWER	USB
COMMON USES	Voiceover, Podcast, Home Music Recording
SIMILAR MICS	Blue Snowball

AUTHORIZATION
The Creative School

Notes:

- "The only mic with a built-in sound engineer"
- Adaptive EQ, de-esser, and levelling automatically smooths audio in real time
- Built-in shock mount and pop filter keeps rumbles and pops to a minimum without any extra accessories
- 3 different modes, "Vocal", "Music", and "Raw"
- Plug n' play, no drivers or setup required
- Rotating base controls volume level, red button is an instant mute, and headphone port is located on the back

Audio-Technica AT899



TYPE	Wired Condenser Lav
PICKUP	Omnidirectional
POWER	48v or 1x AA Battery
COMMON USES	Dialogue, Voiceover, Studio or Documentary Interview
SIMILAR MICS	Countryman B3

AUTHORIZATION
The Creative School

Frequency Response:

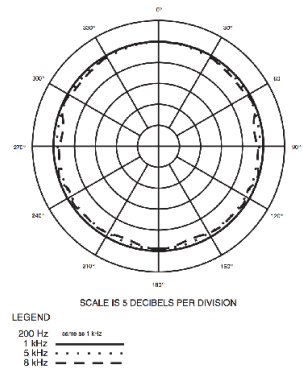
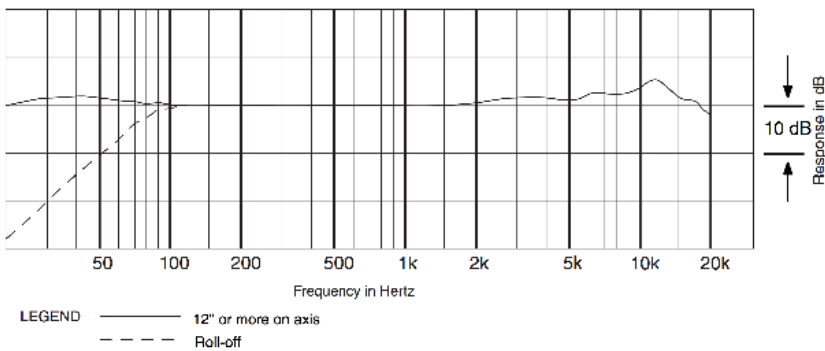

Notes:

- Very discrete, 5mm in diameter
- Low-frequency roll-off switch for reducing pops and rumble
- Great bass response for capturing full-bodied sound

Countryman B3



TYPE Wired Condenser Lav

PICKUP Omnidirectional

POWER 48v

COMMON USES Dialogue, Voiceover, Studio or Documentary Interview

SIMILAR MICS AT899

AUTHORIZATION
The Creative School

Frequency Response:

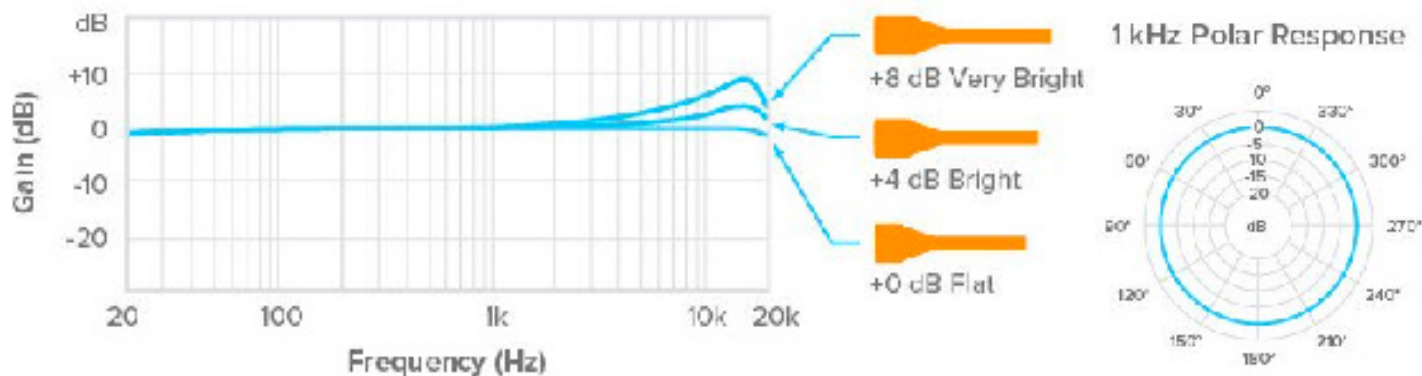

Notes:

- Full spectrum frequency response and ability to handle up to 140 dBA SPL without distortion makes it suitable in any voice recording context

Sony ECM-44B



TYPE Wired Condenser Lav

PICKUP Omnidirectional

POWER 1x AA Battery

COMMON USES Live Studio Interview

SIMILAR MICS ECM-55B

AUTHORIZATION
The Creative School

Frequency Response:

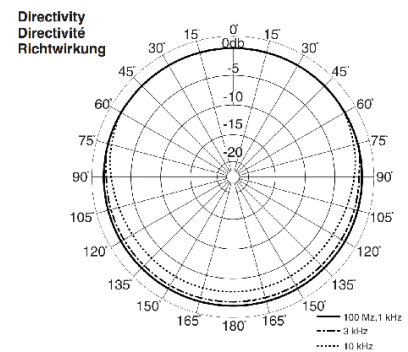
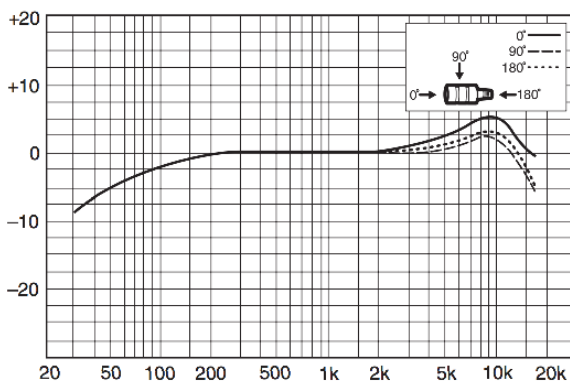

Notes:

- Does NOT take phantom power, must be powered by an internal battery
- Better suited for live and interview application than EFP
- purposes due to limited frequency response

Sony ECM-55B



synhro.co

TYPE Wired Condenser Lav

PICKUP Omnidirectional

POWER 48v or 1x AA Battery

COMMON USES Studio/Documentary
Interview, Dialogue

SIMILAR MICS ECM-44B

AUTHORIZATION
The Creative School

Frequency Response:

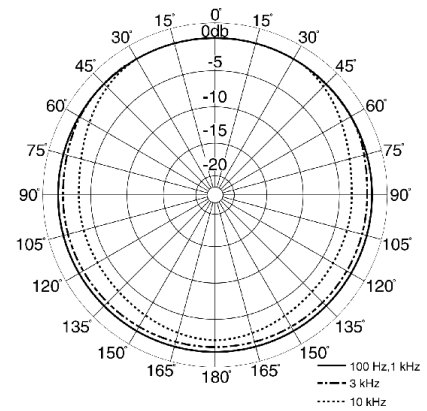
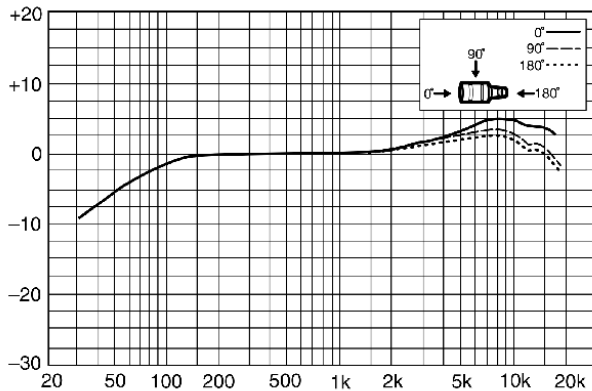

Notes:

- Manufacturer's suggestion: Turn on 10 minutes before use to ensure the most stable performance
- Larger mic head (10mm diameter) provides rich sound reproduction

Sennheiser EW100 G3 w/ ME 2 Mic



TYPE	Wireless Lav
PICKUP	Omnidirectional
POWER	4x AA Battery
COMMON USES	Dialouge, Field Production, Interivew
SIMILAR MICS	None

AUTHORIZATION
The Creative School

Notes:

- Includes lav mic with one wireless transmitter and one reciever
- To find a frequency without any interference: Open the menu on the reciever, go to "Easy Setup" and "Scan New List"
- To easily pair the transmitter with the reciever: Open the menu on the reciever, go to "Sync", open the hatches on both packs and hold them face-to-face, about 6 inches from each other
- Reciever pack can be used in combination with the XLR Mic Transmitter to make any mic wireless

Free Space Binaural Microphone



TYPE	Binaural microphone
PICKUP	Omnidirectional
POWER	Preinstalled 9v battery or 48v
COMMON USES	Immersive binaural soundscape
SIMILAR MICS	None

AUTHORIZATION
The Creative School

Notes:

- Features two matched DPA 4060 CORE hi-sensitivity capsules mounted inside each ear canal delivering a very sensitive and natural binaural sound.
- Flat frequency response and dynamic range of the capsules results in a very open and dynamic binaural realism, especially during very delicate recordings
- Comes standard with a 5/8" microphone stand adapter installed in the base. The microphone stand adapter is removable. The base of the microphone has a 1/4"-20 female thread mounting hole that can be connected to a hot-shoe adapter or used to mount directly onto a tripod or grip handle.

Recorders, Mixers, DAW's, PA's & Speakers

EDC Audio Guidebook

Audio Cart



SPECS

N/A

ACCESSORIES

N/A

AUTHORIZATION: RTA

Behringer X32

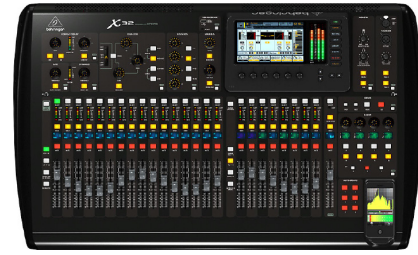

SPECS

40 input, 25-bus digital mixing console. 32 channels

ACCESSORIES

Carrying Case

AUTHORIZATION: RTA

Behringer X32 Compact



SPECS

16-input, 32 channel digital mixing console

ACCESSORIES

Carrying Case

AUTHORIZATION: RTA

Digital Snake



SPECS

Behringer S16, Stagebox for X32 Mixers

ACCESSORIES

N/A

AUTHORIZATION: RTA

iRig Mic Adapter - 1/8"



SPECS

Connects a mic to your phone

ACCESSORIES Cellphone, Microphone, XLR

AUTHORIZATION: The Creative School

iRig - Lightning Connector



SPECS

Connects a mic to your phone

ACCESSORIES Cellphone, Microphone, XLR

AUTHORIZATION: The Creative School

Marantz 661



SPECS

Portable stereo digital audio recorder, mic + 2 line inputs

ACCESSORIES Marantz power supply

AUTHORIZATION: The Creative School

Marantz 661 MKIII



SPECS

Portable stereo digital audio recorder, mic + 2 line inputs

ACCESSORIES Marantz power supply

AUTHORIZATION: The Creative School

Mixers - 2 Channel Field



SPECS

Sound Devices MixPre-D, 2 Channel Field Mixer

ACCESSORIES

2x AA batteries, XLRs, Mics, Recording device

AUTHORIZATION: The Creative School

Mixers - 3 Channel Field



SPECS

Sound Devices 302, 3 Channel Field Mixer

ACCESSORIES

2x AA batteries, XLRs, Mic, Recording device

AUTHORIZATION: The Creative School

Mixers - 6 Channel Field



SPECS

Sound Devices 664, 6 input with integrated recorder

ACCESSORIES

XLRs, Mics, Recording device, NP battery and adapter cup

AUTHORIZATION: RTA

Mixers - Mackie 1202



SPECS

Small 12 channel desktop mixer

ACCESSORIES

Power supply

AUTHORIZATION: The Creative School

Mixers - Mackie 1604



SPECS

16 Channel desktop mixer,
1604-VLZ (Very low noise)

ACCESSORIES

Power Supply

AUTHORIZATION: The Creative
School

Mixers - Onyx 1620



SPECS

16 Channel analog
recording mixer

ACCESSORIES

Power Supply

AUTHORIZATION: The Creative
School

Powered Studio Monitors



SPECS

Alesis M1 Active Reference
Monitors

ACCESSORIES

Power Supply

AUTHORIZATION: RTA

Speakers - Computer



SPECS

Logitech Z100 USB Powered
Speakers

ACCESSORIES

N/A

AUTHORIZATION: The Creative
School

Speakers - Ediol



SPECS

Desktop Speakers (Left and Right)

ACCESSORIES

Power Cable

AUTHORIZATION: The Creative School

Speakers - PA (12", 15")



SPECS

Electrovoice ZLX - 1000W
Powered loudspeaker

ACCESSORIES

PA Speaker Stands, PA
Subwoofer

AUTHORIZATION: RTA

USB Audio Interface



SPECS

Scarlett 2i2 USB Audio
Interface, 4 analog inputs

ACCESSORIES

N/A

AUTHORIZATION: RTA

Zoom - F1



SPECS

2 Channel Digital Multitrack
Recorder, USB

ACCESSORIES

Wired Lavalier

AUTHORIZATION: PRO COM

Zoom - F8



SPECS

8 channel field mixer, 10 channel recording

ACCESSORIES NP Battery, NP Adapter Cup

AUTHORIZATION: RTA

Zoom - H2N



SPECS

Handheld recorder

ACCESSORIES 2x AA Batteries

AUTHORIZATION: The Creative School

Zoom - H4N



SPECS

Portable 4 track recorder, built in X/Y microphone

ACCESSORIES 4x AA Batteries, XLR, Mic, SD card up to 16 gbs

AUTHORIZATION: The Creative School

Zoom - H5



SPECS

4 track recorder, interchangeable mic

ACCESSORIES 4x AA Batteries, XLR, Mic attachments, SD card

AUTHORIZATION: The Creative School

Zoom - H6

**SPECS**

6 track portable recorder,
interchangeable mic

ACCESSORIES

4x AA Batteries, Dual XLR,
Mid-side, Shotgun, Stereo
mic attachments

AUTHORIZATION: RTA, PRO COM